



MODEL: PRO-6MR

6,000 LB. LOW-RISE AUTOMOBILE LIFT

Important Notices:

The floor on which the lift is to be operated must be 4-inch minimum thickness concrete, with steel reinforcement bars, and minimum compressive strength of 3000 psi.

Failure by the purchaser to provide the recommended operating surface could result in unsatisfactory lift performance, property damage, or personal injury.

TABLE OF CONTENTS

Daily Maintenance.....	3
Operating Tips.....	3
Tools Required for On Site Assembly.....	3
On Site Assembly Instructions.....	3
Work Platform Assembly Instructions.....	4
Lift Specifications.....	4
Lift Capacity Scale.....	4
Troubleshooting:	
1. Pump motor will not operate.....	4
2. Power unit switch does not operate properly.....	4
3. Lift mechanism does not move up and down smoothly.....	5
4. Lift does not lift its rated capacity.....	5
5. Cylinders leak under rated load.....	5
6. Lift will not lower.....	5
Parts List.....	6-7
Lift Parts Assembly Views.....	8-10

Daily Maintenance:

1. Insure all bolts are secured and snug with lock washer, nylon lock nuts, or cotter keys.
2. Lift locking mechanism should be lubricated to operate properly.
3. Check spring on locking mechanism for constant tension.
4. Check cylinders and hose for loose connections and leaks.
5. Check oil level in pump reservoir.

Operating Tips:

1. DO NOT attempt to lift more than the units' rated capacity.
2. Lift should only be operated on a level foundation.
3. Remove any potential obstacles that might impede roller travel.
4. The machine or vehicle that is being lifted should be balanced on the lift.
5. Do not remove heavy components from a raised machine or vehicle without first installing adequate supports. The vehicle may become unbalanced and fall.

On Site Assembly Instructions:

1. Mount motor and pump to power unit stand with 4 bolts supplied with the lift. See Fig. #3.
2. Mount the 3/8" hydraulic hose to 3/8" JIC adapter located on the lower end of the Hydraulic splitter. See Fig. #2. Fill reservoir tank with hydraulic oil (SAE 10 weight non-foaming non-detergent) and plug into 110 volt AC power source.
3. The lock release cable should already be installed at the lock end of the lift. Attach the other end of the lock release cable to the brake handle and mount to the power unit stand handle.

OWNER/EMPLOYER RESPONSIBILITIES

The Owner/Employer:

- Shall ensure that lift operators are qualified and that they are trained in the safe use and operation of the lift using the manufacturer's operating instructions; ALI/SM 93-1, *ALI Lifting it Right* safety manual; ALI/ST-90 *ALI Safety Tips* card; ANSI/ALI ALOIM-2000, *American National Standard for Automotive Lifts-Safety Requirements for Operation, Inspection and Maintenance*; ALI/WL Series, *ALI Uniform Warning Label Decals/Placards*; and in the case of frame engaging lifts, ALI/LP-GUIDE, *Vehicle Lifting Points/Quick Reference Guide for Frame Engaging Lifts*.
- Shall establish procedures to periodically inspect the lift in accordance with the lift manufacturer's instructions or ANSI/ALI ALOIM-2000, *American National Standard for Automotive Lifts-Safety Requirements for Operation, Inspection and Maintenance*; and The Employer Shall ensure that lift inspectors are qualified and that they are adequately trained in the inspection of the lift.
- Shall establish procedures to periodically maintain the lift in accordance with the lift manufacturer's instructions or ANSI/ALI ALOIM-2000, *American National Standard for Automotive Lifts-Safety Requirements for Operation, Inspection and Maintenance*; and The Employer Shall ensure that lift maintenance personnel are qualified and that they are adequately trained in the maintenance of the lift.
- Shall maintain the periodic inspection and maintenance records recommended by the manufacturer or ANSI/ALI ALOIM-2000, *American National Standard for Automotive Lifts-Safety Requirements for Operation, Inspection and Maintenance*.
- Shall display the lift manufacturer's operating instructions; ALI/SM 93-1, *ALI Lifting it Right* safety manual; ALI/ST-90 *ALI Safety Tips* card; ANSI/ALI ALOIM-2000, *American National Standard for Automotive Lifts-Safety Requirements for Operation, Inspection and Maintenance*; and in the case of frame engaging lifts, ALI/LP-GUIDE, *Vehicle Lifting Points/Quick Reference Guide for Frame Engaging Lifts*; in a conspicuous location in the lift area convenient to the operator.
- Shall provide necessary lockout/tagout means for energy sources per ANSI Z244.1-1982 (R1993), *Safety Requirements for the Lockout/Tagout of Energy Sources*, before beginning any lift repairs.
- Shall not modify the lift in any manner without the prior written consent of the manufacturer.

Typical Lifting Points

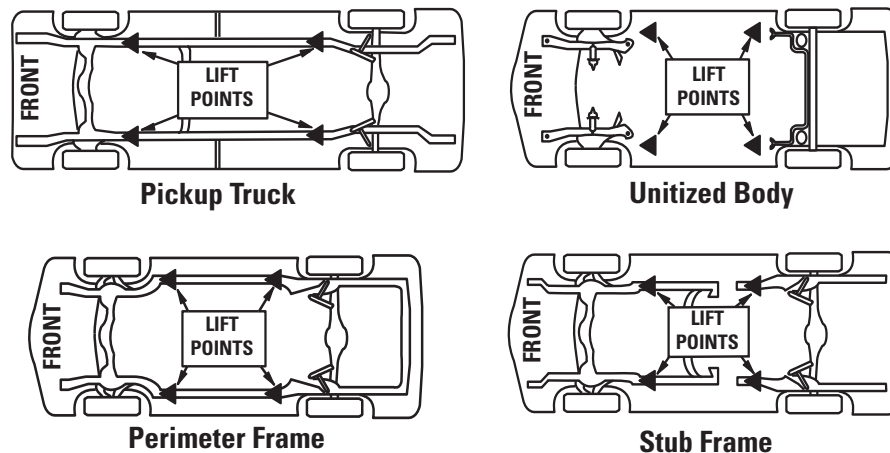



NOTE: Some vehicles may have the manufacturer's Service Garage Lift Point locations identified by triangle shape marks on its undercarriage (reference ANSI/SAE J2184-1992). Also, there may be a label located on the right front door lock face showing specific vehicle lift points. If the specific vehicle lift points are not identified, refer to the "Typical Lift Points" illustrated herein. ALWAYS follow the operating instructions supplied with the lift.



SAFETY WARNING LABELS FOR HINGED FRAME ENGAGING LIFTS

Lift Owner/User Responsibilities:

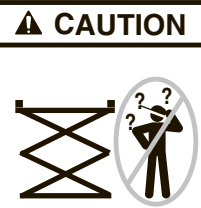
- A.** This Safety Warning placard **SHALL** be displayed in a conspicuous location in the lift area.
- C.** These Safety Warning labels supplement other documents supplied with the lift.
- B.** Use one of the mounting arrangements illustrated on back of this placard.
- D.** Be certain all lift operators read and understand these labels, operating instructions and other safety related information supplied with the lift.

 <p style="font-size: small; text-align: center;">WARNING</p> <p style="font-size: x-small; text-align: center;">Position vehicle with center of gravity midway between adapters.</p>	 <p style="font-size: small; text-align: center;">WARNING</p> <p style="font-size: x-small; text-align: center;">Remain clear of lift when raising or lowering vehicle.</p>	 <p style="font-size: small; text-align: center;">WARNING</p> <p style="font-size: x-small; text-align: center;">Keep feet clear of lift while lowering.</p>
 <p style="font-size: small; text-align: center;">WARNING</p> <p style="font-size: x-small; text-align: center;">Clear area if vehicle is in danger of falling.</p>	 <p style="font-size: small; text-align: center;">WARNING</p> <p style="font-size: x-small; text-align: center;">Avoid excessive rocking of vehicle while on lift.</p>	 <p style="font-size: small; text-align: center;">WARNING</p> <p style="font-size: x-small; text-align: center;">Keep clear of pinch points when lift is moving.</p>

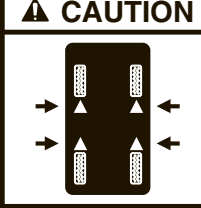
 <p style="font-size: small; text-align: center;">CAUTION</p> <p style="font-size: x-small; text-align: center;">Lift to be used by trained operator only.</p>	<p style="font-size: x-small;">Power Unit: Secure placard near lift controls.</p>  <p style="font-size: x-small;">Lift Control Console: Secure placard in an accessible location.</p> 	<p style="font-size: x-small;">The messages and pictographs shown are generic in nature and are meant to generally represent hazards common to all automotive lifts regardless of specific style.</p> <p style="font-size: x-small;">Funding for the development and validation of these labels was provided by the Automotive Lift Institute, PO Box 1519 New York, NY, 10101-1519.</p> <p style="font-size: x-small;">They are protected by copyright. Set of labels may be obtained from ALI or its member companies.</p> <p style="font-size: x-small;">© 1992 by ALI, Inc. ALIWL300csw</p>
--	--	---

 <p style="font-size: small; text-align: center;">CAUTION</p> <p style="font-size: x-small; text-align: center;">Authorized personnel only in lift area.</p>	 <p style="font-size: small; text-align: center;">CAUTION</p> <p style="font-size: x-small; text-align: center;">Use vehicle manufacturer's lift points.</p>	 <p style="font-size: small; text-align: center;">CAUTION</p> <p style="font-size: x-small; text-align: center;">Always use safety stands when removing or installing heavy components.</p>
--	--	--

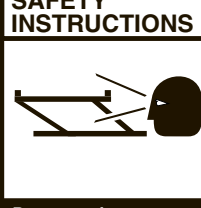
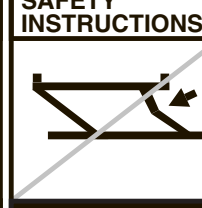
 <p style="font-size: small; text-align: center;">SAFETY INSTRUCTIONS</p> <p style="font-size: x-small; text-align: center;">Read operating and safety manuals before using lift.</p>	 <p style="font-size: small; text-align: center;">SAFETY INSTRUCTIONS</p> <p style="font-size: x-small; text-align: center;">Proper maintenance and inspection is necessary for safe operation.</p>	 <p style="font-size: small; text-align: center;">SAFETY INSTRUCTIONS</p> <p style="font-size: x-small; text-align: center;">Do not operate a damaged lift.</p>
---	---	--

LIFT LOCKOUT/TAGOUT PROCEDURE

Purpose

This procedure establishes the minimum requirements for the lockout of energy that could cause injury to personnel by the operation of lifts in need of repair or being serviced. All employees shall comply with this procedure.

Responsibility

The responsibility for assuring that this procedure is followed is binding upon all employees and service personnel from outside service companies (i.e., Authorized Rotary Installers, contactors, etc.). All employees shall be instructed in the safety significance of the lockout procedure by the facility owner/manager. Each new or transferred employee along with visiting outside service personnel shall be instructed by the owner/manager (or assigned designee) in the purpose and use of the lockout procedure.

Preparation

Employees authorized to perform lockout shall ensure that the appropriate energy isolating device (i.e., circuit breaker, fuse, disconnect, etc.) is identified for the lift being locked out. Other such devices for other equipment may be located in close proximity of the appropriate energy isolating device. If the identity of the device is in question, see the shop supervisor for resolution. Assure that proper authorization is received prior to performing the lockout procedure.

Sequence of Lockout Procedure

- 1) Notify all affected employees that a lockout is being performed and the reason for it.
- 2) Unload the subject lift. Shut it down and assure the disconnect switch is "OFF" if one is provided on the lift.
- 3) The authorized lockout person operates the main energy isolation device removing power to the subject lift.
 - If this is a lockable device, the authorized lockout person places the assigned padlock on the device to prevent its unintentional reactivation. An appropriate tag is applied stating the person's name, at least 3" x 6" in size, an easily noticeable color, and states not to operate device or remove tag.
 - If this device is a non-lockable circuit breaker or fuse, replace with a "dummy" device and tag it appropriately as mentioned above.
- 4) Attempt to operate lift to assure the lockout is working. Be sure to return any switches to the "OFF" position.
- 5) The equipment is now locked out and ready for the required maintenance or service.

Restoring Equipment to Service

- 1) Assure the work on the lift is complete and the area is clear of tools, vehicles, and personnel.
- 2) At this point, the authorized person can remove the lock (or dummy circuit breaker or fuse) & tag and activate the energy isolating device so that the lift may again be placed into operation.

Rules for Using Lockout Procedure

Use the Lockout Procedure whenever the lift is being repaired or serviced, waiting for repair when current operation could cause possible injury to personnel, or for any other situation when unintentional operation could injure personnel. No attempt shall be made to operate the lift when the energy isolating device is locked out.

OPERATING CONDITIONS

Lift is not intended for outdoor use and has an operating ambient temperature range of 41°-104°F (5°-40°C).

Lift Specifications:

Lowered Height	3 7/8"	Voltage	110VAC
Raised Height	48"	Motor Output	1 HP
Overall Width	39 1/2"	Pump Output	3200 psi
Overall Length	88"	Fluid Capacity	6 qt.

Lift Capacity Scale:

This is what the lift will pick up with weight directly on the lifting pads at the specified distances from the floor.

1,500 lbs.	Scissor lift platform fully retracted (with no spacer on the platform attachment bolts).
3,000 lbs.	Scissor lift platform is raised 1 1/2": distance from the floor. (with provided spacer on platform attachment bolts)
4,000 lbs.	Scissor lift platform is raised 2 1/2" distance from the floor. (requires additional spacer)
5,000 lbs.	Scissor lift platform is raised 3 3/8" distance from the floor. (requires additional spacer)
6,000 lbs.	Scissor lift platform is raised 4 3/8" distance from the floor. (requires additional spacer)

Troubleshooting:

1. Pump motor will not operate.
 - Check electrical plug and cord.
 - Check electrical supply breaker.
2. Power unit switch does not operate properly.
 - Contact the manufacturer for a replacement or additional troubleshooting information.
3. Lift mechanism does not move up and down smoothly.
 - Move vehicle location on the lift for more equal weight distribution.
 - Bleed the hydraulic system by first loosening the hose connection at the rod end of both cylinders. Then loosen the hose from fitting (NOT the fitting from the cylinder). Run the

power unit until fluid appears at the hose and fitting connection and hose connection at the rod end. When there is no more air exiting the system, tighten both hose connections.

4. Lift does not lift its rated capacity.

- Move vehicle location on the lift for more equal weight distribution.
- Check the voltage of the electrical supply with the unit run under load. Make sure the pump is getting adequate voltage.

5. Cylinders leak under rated load.

- Check for leaks at the hydraulic hose, fittings, cylinders and pump.
- Contamination may be in the check valve preventing the valve from completely closing.
 1. Hold open the lowering valve by pushing the control lever on the power unit.
 2. At the same time, run the pump for 30 seconds to flush the valve.
 3. Repeat 3 to 4 times.
 4. If cylinders continue to leak down, pump may have a faulty valve, Contact the manufacturer.

6. Lift will not lower.

- Raise lift 1" to 2", squeeze release handle and try again to lower lift.
- Check tension on the release cable.

PRO-6MR PARTS LIST

1	PMR-6001	SAFETY GEAR RACK	1
2	PMR-6002	PIN	1
3	PMR-6003	ROLLER	4
4	PMR-6004	PIN,FLOOR ROLLER	4
5	PMR-6005	CYLINDER BOTTOM PIN	2
6	PMR-6006	PIN	2
7	PMR-6007	SCISSOR PIN	2
8	PMR-6008	SPRING	2
9	PMR-6009	SPRING	2
10	PMR-6010	PIN,TOP ROLLER	2
11	PMR-6011	SPRING,LATCH RESET	2
12	PMR-6012	SAFETY LATCH	1
13	PMR-6013	T SHAFT,LATCH	1
14	PMR-6015	CABLE PULLEY	1
15	PMR-6016	TEE FITTING,HYDRAULIC	1
16	PMR-6017	WASHER	2
17	PMR-6018	SCREW	1
18	PMR-6019	ELBOW FITTING	4
19	PMR-6020	HYDRAULIC HOSE	1
20	30400-9054(B)YZ	45° FITTING	1
21	PMR-6200	SCISSOR FRAME,OUTSIDE	1
22	PMR-6300	SCISSOR FRAME,INSIDE	1
23	PMR-6400	CHANNEL,SAFETY	1
24	PMR-6157	SPRING	4
25	B10-8	BOLT M8x16	4
26	B41-8	FLAT WASHER $\Phi 8$	17
27	B40-8	LOCK WASHER $\Phi 8$	13
28	B34-30-1.5	NUT M30-1.5	2
29	B40-30	LOCK WASHER $\Phi 30$	2
30	B35-6	NUT $\Phi 6$	1
31	B28-6x10	SLOTTED NUT $\Phi 6 \times 10$	1
32	B42-6	WASHER $\Phi 6$	1
33	PMR-6022	SHAFT	1
34	B60-16	SNAP RING $\Phi 16$	2
35	B20-8x20	BOLT M8x20	2
36	B10-8x20	BOLT M8x20	5
37	B20-5x16	BOLT M5x16	1
38	B21-8x16	BOLT M8x16	4
39	PMR-6030D	SAFETY RELEASE CABLE	1
40	YG03-9100	CYLINDER	2
41	B41-6	FLAT WASHER $\Phi 6$	2
42	PMR-6150A	SWING ARMS WELDMENT	4
43	PMR-6021	HYDRAULIC HOSE	2

44	51053-1800	DOLLY WELDMENT	1
44.1	P3545	HYDRAULIC POWER UNIT	1
44.2	B81-21	HANDLE	2
44.3	PMR-6030A	SAFETY RELEASE HANDLE	1
44.4	B52-3x30	COTTER PIN Φ 3x30	2
44.5	B10-8x25	BOLT M8x25	4
44.6	B80-4x2	CASTERS	2
44.7	B41-12C	FLAT WASHER Φ 12,GRADE C	6
44.8	30400-9053YZ	FITTING	1
45	PMR-6100	TOP PLATFORM	1
46	PMR-6131	RUBBER INSERT	8
47	B33-18	NYLON LOCK NUT M18	4
48	PMR-6130A	PAD WELDMENT A	4
49	PMR-6158	WASHER	4
50	PMR-6140A	SCREW WELDMENT	4
51	PMR-6140B	THREADED INSERT WELDMENT	4
52	B85-6	OIL ZERK M6	2
53	B30-8	NUT M8	4
54	PMR-6144	WASHER	4
55	B28-5x10	SCREW M5x10	4
56	B20-8x16	BLOT M8x16	32
57	B60-9	SNAP RING Φ 9	8
58	PMR-6156	SHAFT	4
59	PMR-6155	LIMIT BLOCK	4
60	PMR-6030B	CABLE ADJUST BOLT	1
61	PMR-6031C	NUT	1
62	30400-1999	WASHER	4

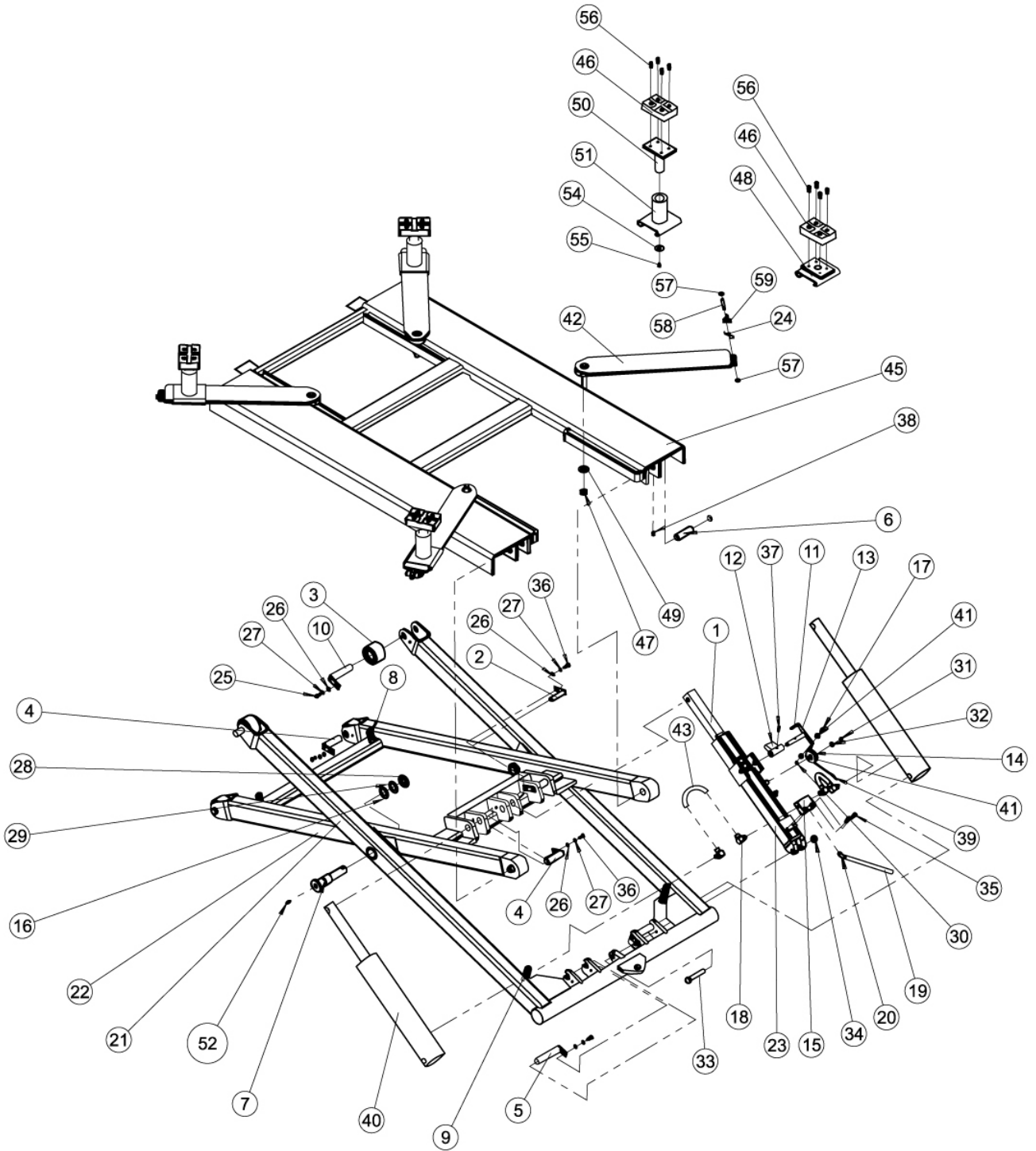

FIG.#1

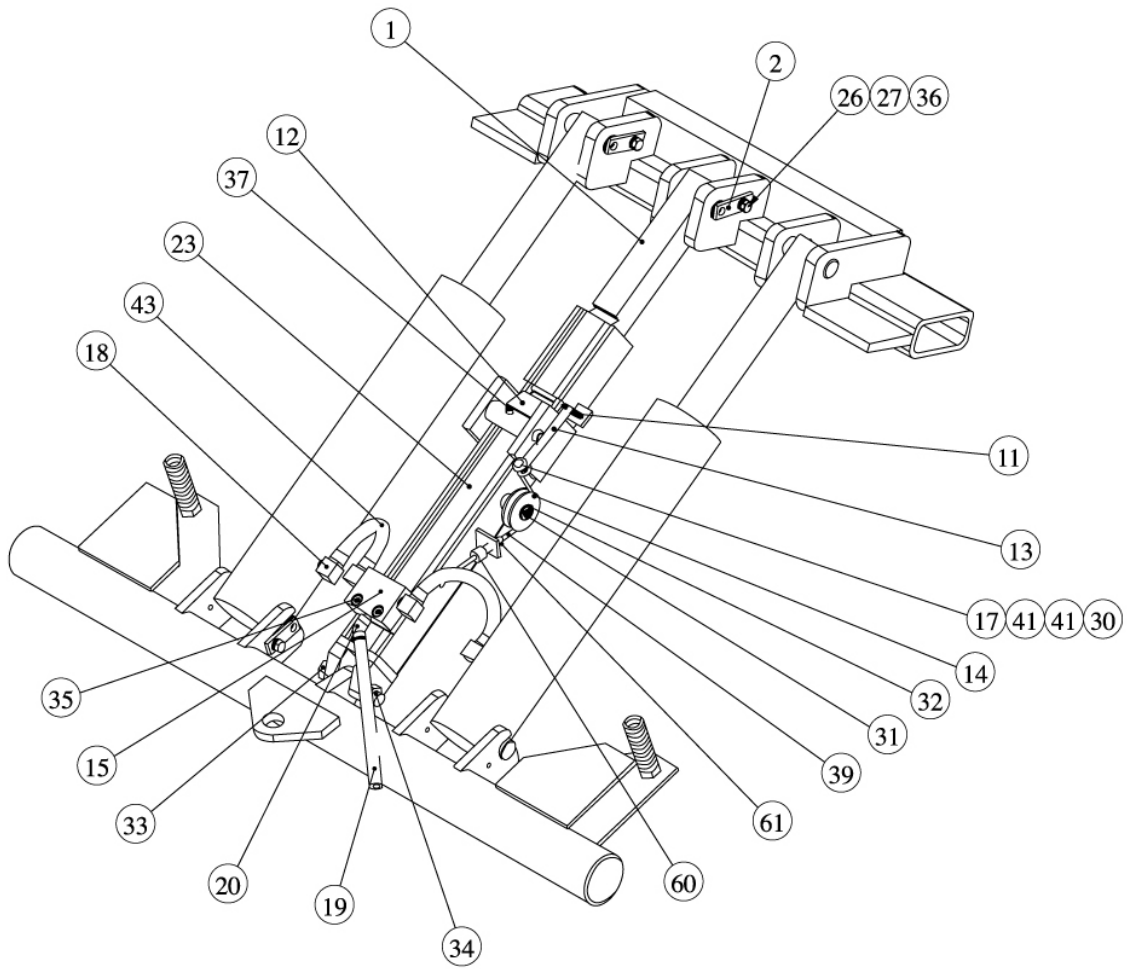

FIG.#2

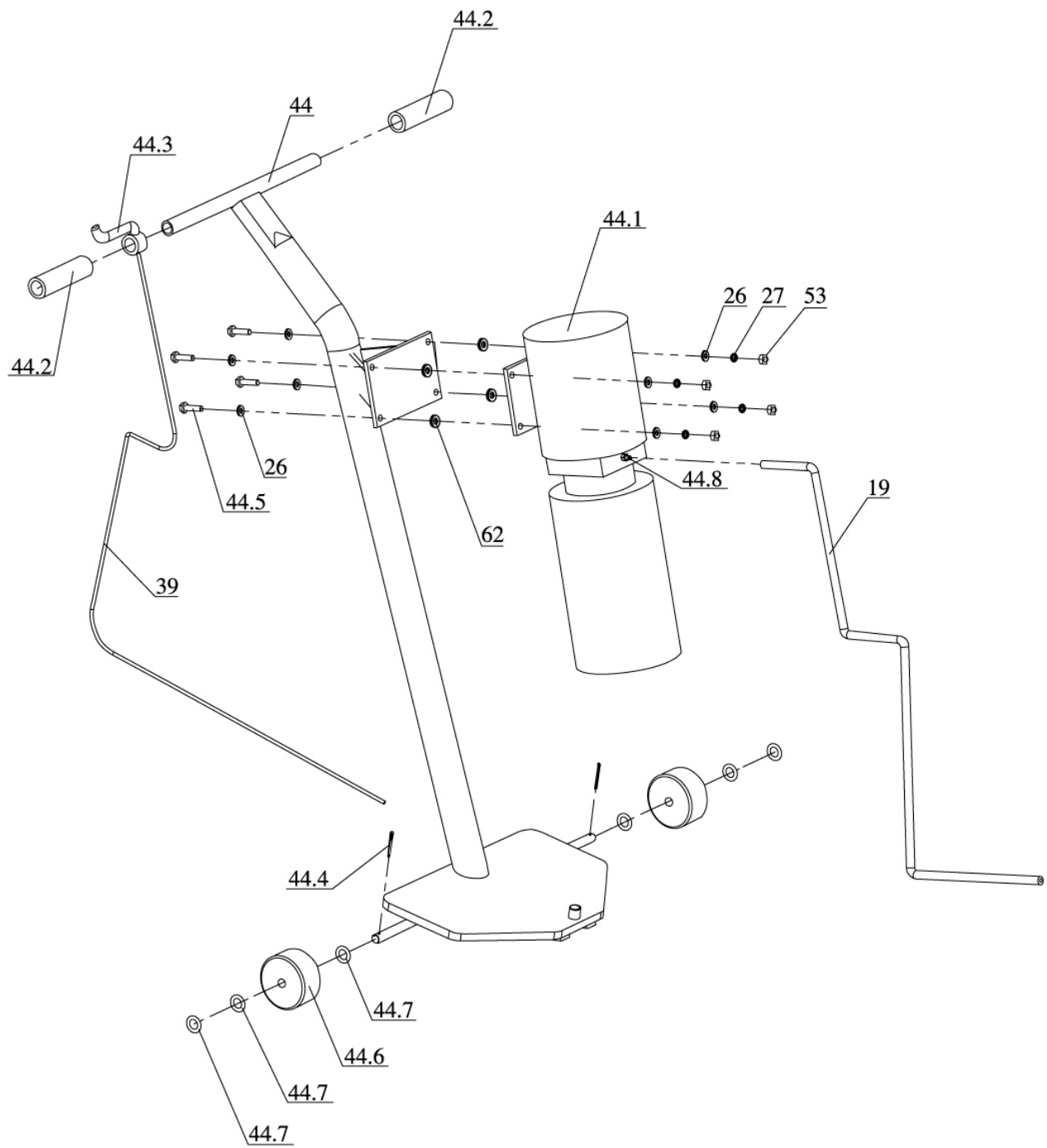

FIG.#3