



Pro9D
Two Column Automotive Lift
9,000lbs. Capacity

Table of Contents

WARRANTY	2
PRO-9D Definition	3
PRO-9D Important Notes	3
PRO-9D BASIC SPECIFICATION.....	4
PRO-9D SET-UP DIMENSIONS.....	4
IMPORTANT FOUNDATION AND ANCHORING INFORMATION.....	5
ANCHORING TIP SHEET.....	6
PREPARATION	6
<i>GENERAL INFORMATION</i>	7
<i>RAISE LIFT</i>	11
<i>LOWER LIFT</i>	11
SAFETY PROCEDURES.....	12
MAINTENANCE SCHEDULE	13
DAILY PRE-OPERATION CHECK (8 HOURS).....	13
<i>WEEKLY MAINTENANCE (40 HOURS)</i>	14
<i>YEARLY MAINTENANCE</i>	14
TROUBLESHOOTING.....	15
OWNER / EMPLOYER RESPONSIBILITIES	16
PRO 9D INSTALLATION / PARTS BREAKDOWN.....	17
PRO 9D PARTS LIST	29

9,000 POUND CAPACITY MODEL: PRO-9D TWO-COLUMN AUTOMOTIVE LIFT

READ THIS ENTIRE MANUAL BEFORE OPERATION BEGINS

RECORD BELOW THE FOLLOWING INFORMATION WHICH IS LOCATED ON THE SERIAL NUMBER DATA PLATE

Serial No. _____
Model No. _____
Date of Install _____

RECORD BELOW THE FOLLOWING CUSTOMER INFORMATION

Company Name _____
Contact Person * _____
Street Address _____
City _____
State _____
Phone _____
Fax _____
Email * _____

* Optional Fields

WARRANTY

The structural components on your new automotive lift are warranted for five years on equipment. Operating components are warranted one year to the original purchaser, to be free of defects in material and workmanship.

The manufacturer shall repair or replace at their option for this period those parts returned to the factory freight prepaid which prove after inspection to be defective.

This warranty only applies to the original purchaser of the equipment. This warranty does not extend to defects caused by ordinary wear, abuse, misuse, shipping damage, or damage as the result of improper maintenance.

This warranty is exclusive and in lieu of all other warranties expressed or implied.

In no event shall the manufacturer be liable for special, consequential or incidental damages for the breach or delay in performance of the warranty.

The manufacturer reserves the right to make design changes or add improvements to its product line without incurring any obligation to make such changes on product sold previously.

This warranty shall be governed under the laws of the state of Texas, and shall be subject to the exclusive jurisdiction of the Court in the state of Texas in the county of Tarrant.

PRO-9D Definition

This lift is a 9,000 lb. capacity, two-column lift. The safety system in this lift is attached to the back of the carriage to provide a single point release that saves time when operating.

PRO-9D Important Notes

Please read the Safety Procedures and operation instructions in this manual before operating the lift. Proper installation is very important. To minimize the chance of making an error in installation, please read this manual through carefully before beginning installation. Check with building owner and/or architect's building plans when applicable. The lift should be located on a relatively level floor with 4" thick, 3000 psi sufficiently cured concrete.

This is a vehicle lift installation / operation manual and no attempt is made or implied herein to instruct the user in lifting methods particular to an individual application. Rather, the contents of this manual are intended as a basis for operation and maintenance of the unit as it stands alone or as it is intended and anticipated to be used in conjunction with other equipment.

Proper application of the equipment described herein is limited to the parameters detailed in the specifications and the uses set forth in the descriptive passages. Any other proposed application of this equipment should be documented and submitted in writing to the factory for examination. The user assumes full responsibility for any equipment damage or personal injury that occurs as the result of alteration of the equipment described in this manual or any subsequent damages.

PRO-9D BASIC SPECIFICATION

Capacity	9,000 lbs
Lifting Time	45 Seconds
Overall Height	142-1/2"
Overall Width (Including Power Unit)	140"
Between Columns	110-1/4"
Drive Through	92-1/4"
Height Shut-Off	134-1/2"

PRO-9D NINE TWO POST LIFT

SET-UP DIMENSIONS

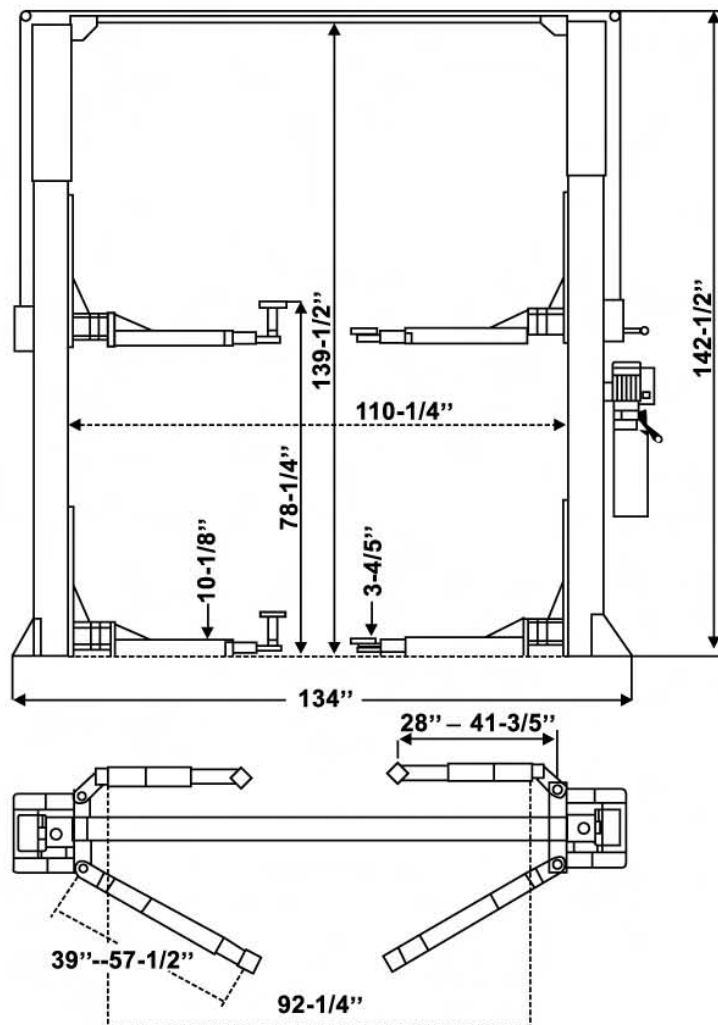

PRO 9D Two-Column Automotive Lift

IMPORTANT FOUNDATION AND ANCHORING INFORMATION

- 1. Concrete shall have compression strength of at least 3,000 PSI and a minimum thickness of 4" in order to achieve a minimum anchor embedment of 3 ¼". When using the standard supplied ¾" x 5 ½" long anchors; if the top of the anchor exceeds 2 ¼" above the floor grade, you DO NOT have enough embedment.**
- 2. Use the existing holes in column base plate as a guide for drilling the ¾" diameter holes into the concrete. Maintain a 6" minimum distance from any slab edge or seam. Hole to hole spacing should be a minimum 6 ½" in any direction. Concrete thickness or hole depth should be a minimum of 4".**
- 3. CAUTION: DO NOT install on asphalt or other similar unstable surface. Columns are supported only by anchoring in floor.**
- 4. Using the horseshoe shims provided, shim each column base as required until each column is plumb. If one column has to be elevated to match the plane of the other column, full size base shim plates should be used (Reference Shim Kit). Torque anchors to 85 ft-lbs. Shim thickness MUST NOT exceed ½" when using the 5 ½" long anchors provided with the lift. Adjust the column extensions plumb.**
- 5. If anchors do not tighten to 85 ft-lbs. installation torque, replace the concrete under each column base with a 4' x 4' x 6" thick 3,000 PSI minimum concrete pad keyed under and flush with the top of existing floor. Allow concrete cure before installing lifts and anchors.**

ANCHORING TIP SHEET

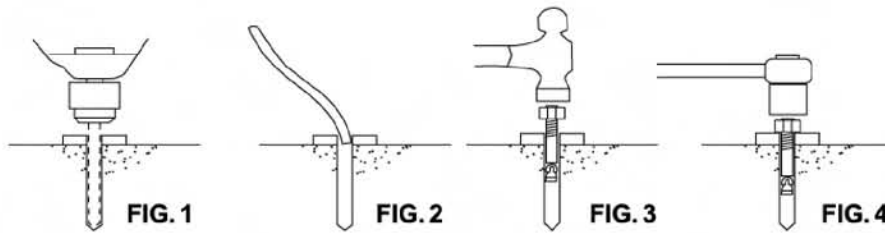

1. **Anchors must be at least 6" from the edge of the slab or any seam.**
2. **Use a concrete hammer drill with a carbide tip, solid drill bit the same diameter as the anchor, 3/4". (.775 to .787 inches diameter). Do not use excessively worn bits or bits which have been incorrectly sharpened.**
3. **Keep the drill in a perpendicular line while drilling.**
4. **Let the drill do the work. Do not apply excessive pressure. Lift the drill up and down occasionally to remove residue to reduce binding.**
5. **Drill the hole to depth equal to the length of anchor.**
6. **For better holding power blow dust from the hole.**
7. **Place a flat washer and hex nut over threaded end of anchor, leaving approximately 1/2 inch of thread exposed carefully tap anchor. Do not damage threads. Tap anchor into the concrete until nut and flat washer are against base plate. Do not use an impact wrench to tighten. Tighten the nut, two or three turns on average concrete (28-day cure). If the concrete is very hard only one or two turns may be required. If the top of the anchor exceeds 2-1/4" above the floor you do not have enough embedment. Check each anchor bolt with torque wrench to 85 foot pounds.**

PREPARATION

The installation of this lift is relatively simple and can be accomplished by 2 men in a few hours. The following tools and equipment are needed:

Appropriate lifting equipment

AW 32, 46 or other good grade Non-Detergent Hydraulic Oil SAE-10 (12 quarts)

Chalkline and 12' Tape Measure

Rotary Hammer Drill with 3/4" Drill Bit. Core Drill ReBar Cutter recommended

Transit and a 4' Level

Sockets and Open Wrench set, 1/2" thru 1-1/2" (1-1/8" for 3/4" Anchors)

Locking Pliers, 8mm Socket Head Wrench

GENERAL INFORMATION

1. Any freight damage must be noted on the freight bill before signing and reported to the freight carrier with a freight claim established. Identify the components and check for shortages. If shortages are discovered, contact Hanmecson International, Inc. immediately.
2. Consult building owner and / or architect's plans when applicable to establish the best lift location. The lift should be located on a relatively level floor with 4" minimum thickness, 3000 psi concrete slab that has been properly cured. **There can be no cracks in the slab within 36" of the base plate location, and no seams in the foundation within 6" of its location! Remember: any structure is only as strong as the foundation on which it is located!**

Check for ceiling clearance first to confirm the lift can be set up in your bay!

- STEP 1:** After unloading the lift, place it near the intended installation location.
- STEP 2:** Remove the shipping bands and packing materials from the lift. The power unit and cylinders will be unpacked from the top.
- STEP 3:** Open the wrapping from the upper column and carefully remove the parts from inside. Unbolt the column from the shipping brackets. Unbolt the up-rights (Item # 2 in the parts list) from the columns and assemble it to the column (Item # 1 & 28 in the parts list). See Fig. # 4.
- STEP 4:** Unpack the cylinders and open the oil port on each cylinder by unscrewing the black plastic cap. Move the carriage up about 20" to 25". Next, carefully slide the cylinder inside from the bottom of the carriage. The oil port will face the backside of the column and the notch on the bottom of the cylinder will fit into the hole in the center of the base plate.
- STEP 5:** Position the columns facing each other 107-1/4" inside base plates (see fig. 7). Square the columns by measuring diagonally from corner points on base plates (within 1/4").
- STEP 6:** Using a 3/4" diameter concrete drill, drill the anchor holes thru the main side column, installing anchors as you go. Use a block of wood or rubber mallet to drive anchor bolts in. Drill to a minimum depth of 4" to insure maximum holding power. Drilling thru concrete (recommended) will allow the anchor to be driven thru the bottom if the anchor needs to be replaced later.

- STEP 7:** Using a level, check column for side-to-side plumb and front-to-back plumb. If needed, use horseshoe shims provided by placing shims underneath the base plate and around the anchor bolt. This will prevent bending the column bottom plates (Shim thickness should not exceed $\frac{1}{2}$ "). Tighten anchor bolts to 85 ft-lbs. of torque.
- STEP 8:** Install the overhead cross beam. This cross beam has two pieces, to be connected by five (5) bolts in the center of the beam. Be sure to bolt them together by installing the bolts from inside the cross beam out. This is to avoid interference with the cable when operating the lift. Next, install the cross beam between two columns as shown on Fig. 3.
- STEP 9:** After fastening the cross beam, check and confirm that the remaining column is plumb.
- STEP 10:** Secure the remaining column by duplicating STEP 6 and STEP 7
- STEP 11:** Install the safety latch on both side columns as shown on Fig. 5 and 6. Connect the safety release cable (parts #33) between two latches. Check that the tension of the cable is tight. Pull the single point release handle several times and check the tension again by making sure both latches release at the same time when the handle is pulled.
- STEP 12:** Mount the power unit on the main side leg to the power unit bracket using the four $\frac{5}{16}$ " bolts and nuts. Connect the power unit to the fitting installed on the back of the main leg by using a short hose supplied. See Fig. 9.
- STEP 13:** Connect the equalizing cables (Item #32 on parts list) as shown in Fig. # 8. Do not tighten at this stage of assembly.

NOTE!!!

The cable stud that connects to the front right corner of the carriage should be connected first by pulling the stud through the carriage hole and up where it is easy to be held by locking pliers. Pull the stud back into place after threading at least $\frac{1}{2}$ " of the stud past the locknut. Connect the other ends to the rear right corners of the carriage with at least $\frac{1}{2}$ " of thread showing past the lock nut (cables run on the inside of the carriage). It may be necessary to manually raise both carriages above the cylinder to provide enough space to use the locking pliers. Make sure the carriage is set in the LOCK position.

- STEP 14:** Adjust the carriage cable tension. This is accomplished by tightening the carriage adjustment nut on top of each carriage. The rear carriage adjustment nut adjusts the opposite post carriage height. The left post carriage nut adjusts the right column carriage, and the right column carriage nut adjusts the left column carriage. Adjust each cable to approximately 1/2" side-to-side play. Check the latch releases to insure the carriage is still engaged in the appropriate latch.
- STEP 15:** Install all four swing arms, readjust the arm lock preinstalled to make sure that gear rack are engaging the moon gear on the arm properly.
- STEP 16:** Remove the vent plug from the power unit and fill the reservoir. Use a Ten Weight (SAE-10) non-foaming, non-detergent hydraulic fluid. The unit will hold approximately twelve quarts of fluid.
- STEP 17:** Make the Electrical hookup to the power unit; 220V Single Phase. It is recommended that a 220 Volt, 30 Amp twist lock plug be installed in the power line just ahead of the power unit. Use wire capable of supporting a 30-amp circuit.

WARNING!!!

The wiring must comply with local code. Have a certified electrician make the electrical hook-up to the power unit. Protect each circuit with time delay fuse or circuit breaker; 208v-230v single phase. 60 Hz 30 amp. Motor can not run on 50 Hz with out a physical change to motor.

- STEP 18:** Locate each hole in the center of the up-rights, approximately 6" below the top edge, on the same side of the columns as the power unit. Install the two eye-bolts to the outside of each up-right with the hardware provided. (Fig. #12)

Insert the cable through the eye-bolt in the slave column side and secure with crimp fitting. Run cable across to the motor column side through the eye-bolt and down to the motor. Insert cable through the pull-pin on top of the motor and temporarily secure with locking pliers or small clamp.

Operate lift and apply pressure to the safety cable to insure motor shuts off prior to any part of vehicle coming in contact with cross-rail.

Adjust cable if necessary and secure with crimp fitting. Remove any excess cable with wire cutters.

STEP 19: Do not place any vehicle on the lift at this time. Cycle the lift up and down several times to insure latches engage properly and all air is removed from the system. To lower the lift, first raised the lift to clear the latches and then pull down the safety release handle to lower the lift. If latches function out of sync, tighten the cable on the latch that engages first.

Safety and Operating Instructions

Only authorized personnel are to operate lift

Read operating and safety procedures manual completely before operating lift.

- Properly maintain and inspect lift in accordance to owner's manual.
- Do not operate a lift that is damaged or in need of repair.
- Allow only authorized personnel in the lift bay.
- Stay clear of Lift when raising or lowering (NO RIDERS)
- Keep hands and feet away from pinch points at all times.
- Never override the Lifts operating and safety controls.
- If a vehicle is suspected of falling, clear area immediately.
- Do not rock vehicle while positioned on lift.
- Always use safety jack stands when removing or installing heavy components.

Vehicle Loading

- Position vehicle for proper weight distribution (center of gravity should be midway between adapters).
- Swing arms under vehicle to allow adapters to contact at the manufacturer's recommended pickup points.
- Use caution before lifting pickup trucks, suv's and other framed vehicles. The individual axle weight capacity should not exceed 1/2 of lift capacity.
- Make sure vehicle is neither front nor rear heavy.

Raising Lift

- Push Up switch to raise lift (make sure arm restraints engage or stop and slightly move arm to allow gear to mesh) until tires clear floor.
- Stop and check for secure contact on adapters and vehicle weight distribution. If secure raise to desired height.
- ALWAYS lower the lift into the nearest lock position by pressing the lower lever to relieve the hydraulic pressure and let the latch set right in a lock position.
- Never work under a lift that is not in the locked position.

Lowering Lift

- Clear all obstacles from under lift and vehicle and ensure only the lift operator is in the lift area.
- Stay clear of lift and raise the lift off the safety locks.
- Pull safety latch releases and press the lower lever to begin descent.
- Unload lift by first completely lowering lift, then swinging arms to drive-thru position before moving vehicle.

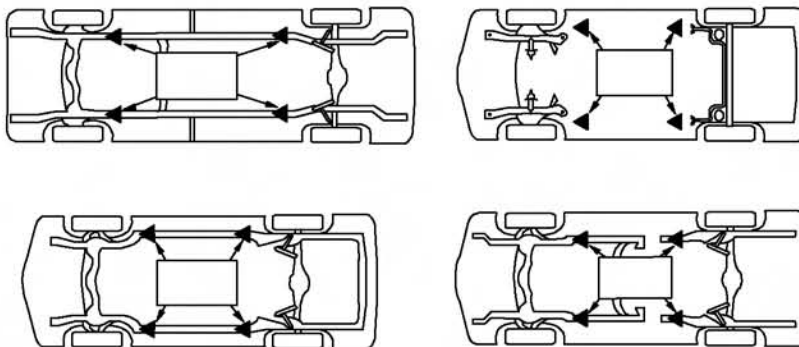











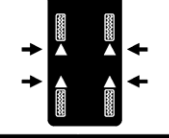

Lift Points Note:

Refer to the manufacturer's specific vehicle lifting points. Some vehicles display these points on a label inside the right front door lock face or are identified by triangle shape marks on the vehicle's undercarriage, reference SAE J2184.

Safety Instructions:

1. **Do not raise a vehicle on the lift until the installation is completed as described in this manual.**
2. **Anyone who will be in the vicinity of the lift** when it is in use should read and refer to the following publications supplied with this lift:
 - “INSTALLATION AND OWNERS MANUAL”, I MAN 991022
 - “LIFTING IT RIGHT”, ALI SM93-1.
 - “AUTOMOTIVE LIFT SAFETY TIPS”, ALI-ST90.
 - “VEHICLE LIFTING POINTS FOR FRAME ENGAGING LIFTS”, ALI/LP-GUIDE.
 - “SAFETY REQUIREMENTS FOR OPERATION, INSPECTION, AND MAINTENANCE”, ANSI/ALI ALOIM-1994.
3. **Technicians** should be trained to use and care for the lift by familiarizing themselves with the publications listed above. The lift should never be operated by an untrained person.
4. **Always position the arms and adapters properly out of the way** before pulling the vehicle into, or out of the bay. Failure to do so could damage the vehicle and/or the lift.
5. **Do not overload the lift.** The capacity of the lift is shown on cover of this document.
6. **Positioning the vehicle** is very important. Only trained technicians should position the vehicle on the lift. Never allow anyone to stand in the path of the vehicle as it is being positioned.
7. **Position the arms to the vehicle manufacturer’s recommended pickup points.** Raise the lift until contact is made with the vehicle. Make sure that the arms have properly engaged the vehicle before raising the lift to a working height.
8. **Keep everyone clear of the lift when the lift is moving, the locking mechanism is disengaged, or the vehicle is in danger of falling.**
9. **Unauthorized personnel** should never be in the shop area when the lift is in use.
10. **Inspect the lift daily.** The lift should never be operated if it has damaged components, or is malfunctioning. Only qualified technicians should service the lift. Replace damaged components with manufacturer’s parts, or equivalent.
11. **Keep the area around the lift clear** of obstacles.
12. **Never** override the self-returning lift controls.
13. **Use safety stands** when removing or installing heavy vehicle components.
14. **Avoid excessive rocking** of the vehicle when it is on the lift.
15. **To reduce the risk of personal injury**, keep hair, loose clothing, fingers, and all body parts away from moving parts.
16. **To reduce the risk of electric shock**, do not use the lift when wet, do not expose the lift to rain.
17. **To reduce the risk of fire**, do not operate equipment in the vicinity of open containers of flammable liquids (gasoline).

18. Use the lift only as described in this manual, use only manufacturer's recommended attachments.
19. Unusual vehicles, such as limousines, RV's, and long wheelbase vehicles, may not be suitable for lifting on this equipment. If necessary, consult with the manufacturer or the manufacturer's representative.
20. The troubleshooting and maintenance procedures described in this manual can be done by the lift's owner/employer. Any other procedure should only be performed by trained lift service personnel. These restricted procedures include, but are not limited to, the following: cylinder replacement, carriage and safety latch replacement, and leg replacement.
21. **Anyone who will be in the vicinity of the lift** when it is in use should familiarize themselves with following Caution, Warning, and Safety related decals supplied with this lift, and replace them if they are illegible or missing:

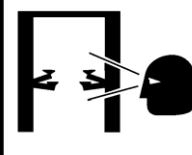
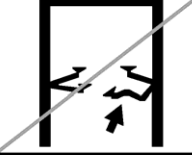
<p>CAUTION</p>  <p>Lift to be used by trained operator only.</p>	<p>CAUTION</p>  <p>Authorized personnel only in lift area.</p>	<p>WARNING</p>  <p>Clear area if vehicle is in danger of falling.</p>	<p>WARNING</p>  <p>Position vehicle with center of gravity midway between adapters.</p>		
<p>CAUTION</p>  <p>Use vehicle manufacturer's lift points.</p>	<p>CAUTION</p>  <p>Always use safety stands when removing or installing heavy components.</p>	<p>WARNING</p>  <p>Remain clear of lift when raising or lowering vehicle.</p>	<p>WARNING</p>  <p>Avoid excessive rocking of vehicle while on lift.</p>		
<p>CAUTION</p>  <p>Use height extenders when necessary to ensure good contact.</p>	<p>CAUTION</p>  <p>Auxiliary adapters may reduce load capacity.</p>	<p>WARNING</p>  <p>Do not override self-closing lift controls.</p>	<p>WARNING</p>  <p>Keep feet clear of lift while lowering.</p>		
<p>The messages and pictographs shown are generic in nature and are meant to generally represent hazards common to all automotive lifts regardless of specific style.</p> <p>Funding for the development and validation of these labels was provided by the Automotive Lift Institute, PO Box 33116 Indialantic, FL 32903-3116.</p> <p>They are protected by copyright. Set of labels may be obtained from ALI or its member companies.</p> <p>© 1992 by ALI, Inc. ALI/WL101c</p>		<p>The messages and pictographs shown are generic in nature and are meant to generally represent hazards common to all automotive lifts regardless of specific style.</p> <p>Funding for the development and validation of these labels was provided by the Automotive Lift Institute, PO Box 33116 Indialantic, FL 32903-3116.</p> <p>They are protected by copyright. Set of labels may be obtained from ALI or its member companies.</p> <p>© 1992 by ALI, Inc. ALI/WL101w</p>		<p>SAFETY INSTRUCTIONS</p>  <p>Read operating and safety manuals before using lift.</p>	<p>SAFETY INSTRUCTIONS</p>  <p>Proper maintenance and inspection is necessary for safe operation.</p>
				<p>SAFETY INSTRUCTIONS</p>  <p>Do not operate a damaged lift.</p>	<p>The messages and pictographs shown are generic in nature and are meant to generally represent hazards common to all automotive lifts regardless of specific style.</p> <p>Funding for the development and validation of these labels was provided by the Automotive Lift Institute, PO Box 33116 Indialantic, FL 32903-3116.</p> <p>They are protected by copyright. Set of labels may be obtained from ALI or its member companies.</p> <p>© 1992 by ALI, Inc. ALI/WL101s</p>

Monthly Maintenance:

1. With lift lowered check the hydraulic fluid level. If necessary add oil as described in the Installation Instruction section of this manual
2. Check carriage latch synching: Latches should click at the same time. If necessary adjust cables as described in the Installation Instruction section of this manual.
3. Check tightness of all bolts.
4. Check anchor bolt tightness. If the anchor bolts are loose, they should be re-torqued to 90ft/lbs.
 - Check the nuts for tightness every week for the first month, and every month afterwards.
5. Replace worn or broken parts only with lift manufacturer's parts, or their equivalent.

Troubleshooting:

1. The power unit does not run:
 - Check electrical supply breaker, or fuse.
 - Check micro-switch and connections in motor control box.
 - Check voltage to the motor.
2. The power unit runs but does not raise the lift:
 - Check the oil level.
 - Check that the lowering valve is not stuck open.
 - Check the connections and components on the suction side of the pump.
3. The power unit raises the lift empty, but will not lift a vehicle.
 - Make sure the vehicle is not above the rated capacity of the lift.
 - Make sure the vehicle is positioned properly.
 - Clean the lowering valve by running the power unit for 30 seconds while holding the lowering valve open.
 - Check the motor voltage.
4. Lift drifts down.
 - Check for external leaks.
 - Clean the lowering valve by running the power unit for 30 seconds while holding the lowering valve open. Repeat this procedure three times.
 - Clean the check valve seat.
5. Slow Lifting and/or oil foaming up.
 - Check that oil used meets the specification in the Installation Instruction section of this manual.
 - Tighten all suction line fittings.

6. Anchors continually work loose
 - If holes were drilled too large relocate the lift per the Installation Instruction section of this manual.
 - Floor is not sufficient to provide the necessary resistance, remove an area of concrete and repour as described in the Installation Instruction section of this manual.
7. Lift does not raise and lower smoothly.
 - Reposition vehicle for a more even weight distribution.
 - Check the four inside corners of the two legs for roughness. Any rust or burrs must be removed with 120 grit emery cloth.
 - Lubricate the leg corners with heavy duty bearing grease.
 - Use a level to check the legs for vertical alignment both side to side and front to back. Shim the legs as necessary per the Installation Instruction section of this manual.
 - Check the oil level.
 - Make sure there is no air in the hydraulic lines, bleed system as described in the Installation Instruction section of this manual.
8. The lift will only lower approximately, 1” then stops.
 - Check that the safety latch pull rods are disengaged.
9. Power Unit will not stop running
 - Switch is damaged, **turn off power to the lift** and replace switch.

6. Lift Lockout/Tagout Procedure

Purpose

This procedure establishes the minimum requirements for the lockout of energy that could cause injury to personnel by the operation of lifts in need of repair or being serviced. All employees shall comply with this procedure.

Responsibility

The responsibility for assuring that this procedure is followed is binding upon all employees and service personnel from outside service companies (i.e., Authorized Rotary Installers, contactors, etc.). All employees shall be instructed in the safety significance of the lockout procedure by the facility owner/manager. Each new or transferred employee along with visiting outside service personnel shall be instructed by the owner/manager (or assigned designee) in the purpose and use of the lockout procedure.

Preparation

Employees authorized to perform lockout shall ensure that the appropriate energy isolating device (i.e., circuit breaker, fuse, disconnect, etc.) is identified for the lift being locked out. Other such devices for other equipment may be located in close proximity of the appropriate energy

isolating device. If the identity of the device is in question, see the shop supervisor for resolution. Assure that proper authorization is received prior to performing the lockout procedure.

Sequence of Lockout Procedure

- 1) Notify all affected employees that a lockout is being performed and the reason for it.
- 2) Unload the subject lift. Shut it down and assure the disconnect switch is “OFF” if one is provided on the lift.
- 3) The authorized lockout person operates the main energy isolation device removing power to the subject lift.
 - If this is a lockable device, the authorized lockout person places the assigned padlock on the device to prevent its unintentional reactivation. An appropriate tag is applied stating the person’s name, at least 3” x 6” in size, an easily noticeably color, and states not to operate device or remove tag.
 - If this device is a non-lockable circuit breaker or fuse, replace with a “dummy” device and tag it appropriately as mentioned above.
- 4) Attempt to operate lift to assure the lockout is working. Be sure to return any switches to the “OFF” position.

Restoring Equipment to Service

- 1) Assure the work on the lift is complete and the area is clear of tools, vehicles, and personnel.
- 2) At this point, the authorized person can remove the lock (or dummy circuit breaker or fuse) & tag and activate the energy isolating device so that the lift may again be placed into operation.

Rules for Using Lockout Procedure

Use the Lockout Procedure whenever the lift is being repaired or serviced, waiting for repair when current operation could cause possible injury to personnel, or for any other situation when unintentional operation could injure personnel. No attempt shall be made to operate the lift when the energy isolating device is locked out.

7. Operating Conditions

Lift is not intended for outdoor use and has an operating ambient temperature range of 41°-104°F (5°-40°C).

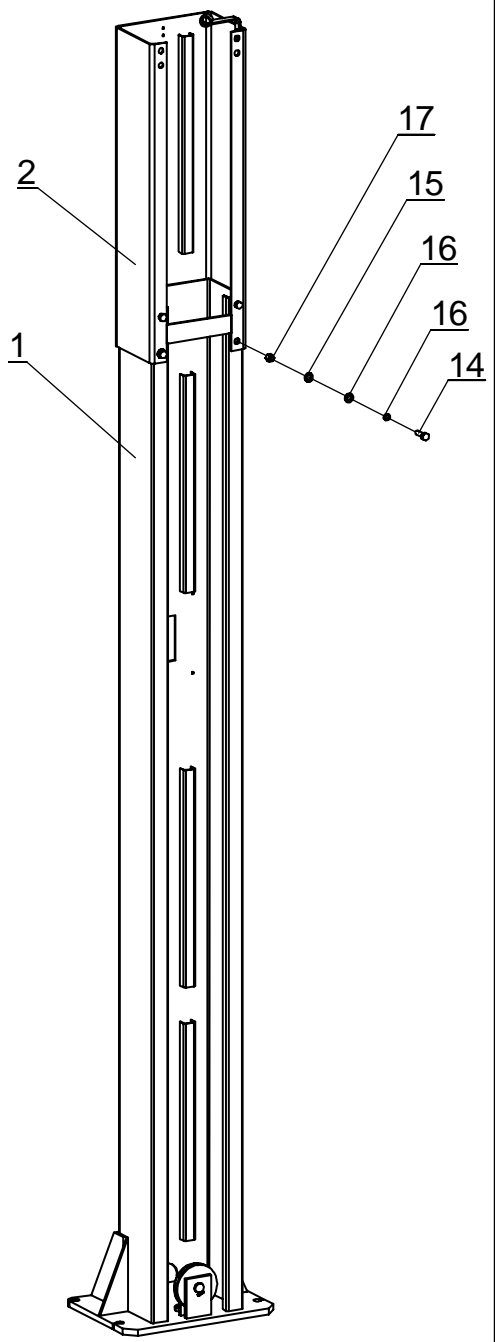

Figure 1

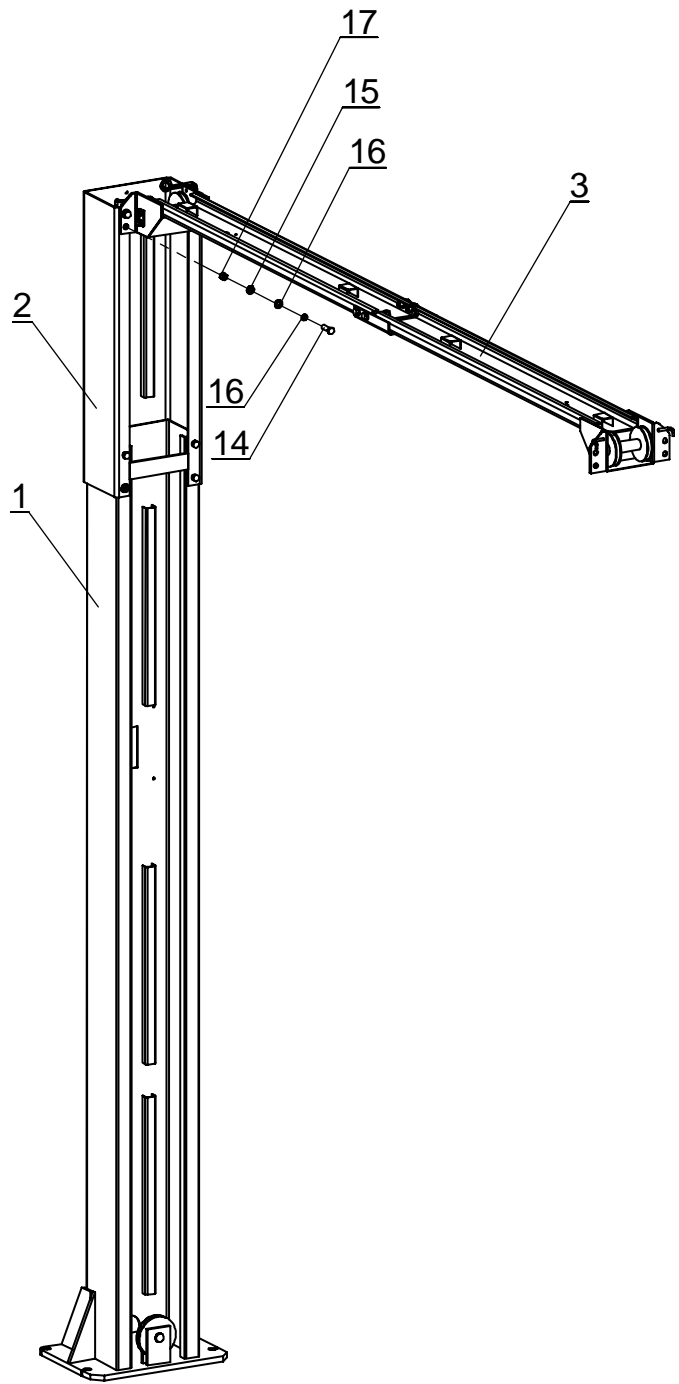

Figure 2

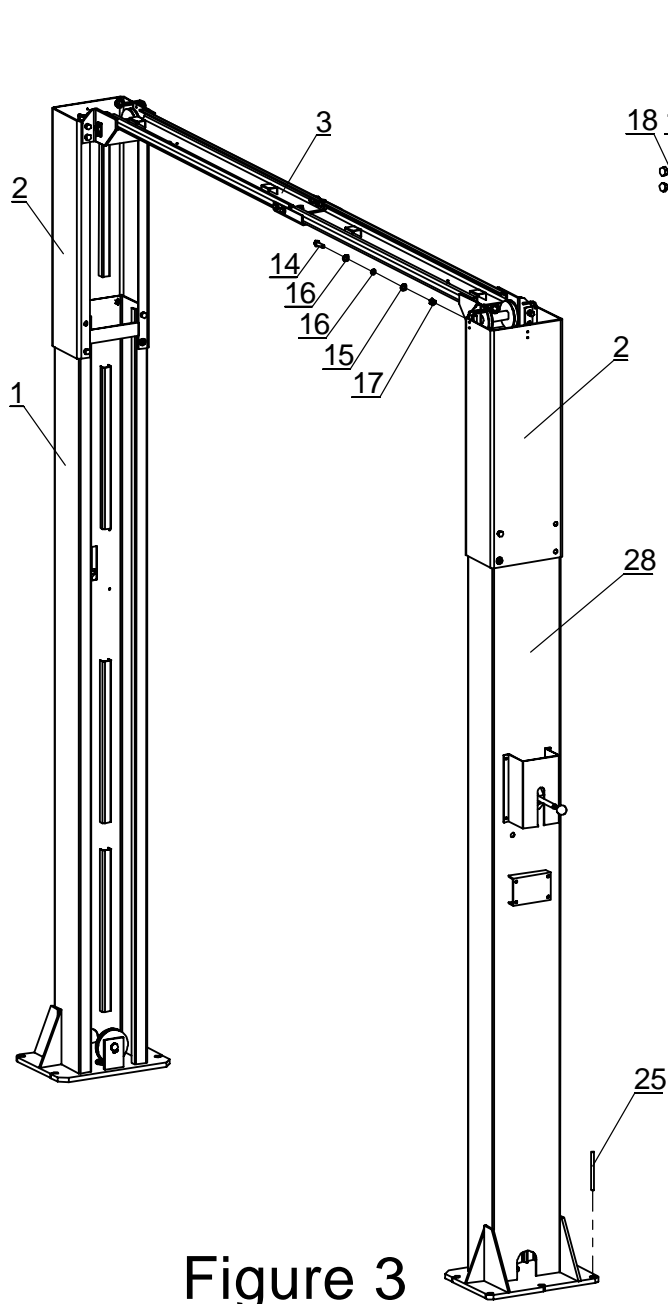

Figure 3

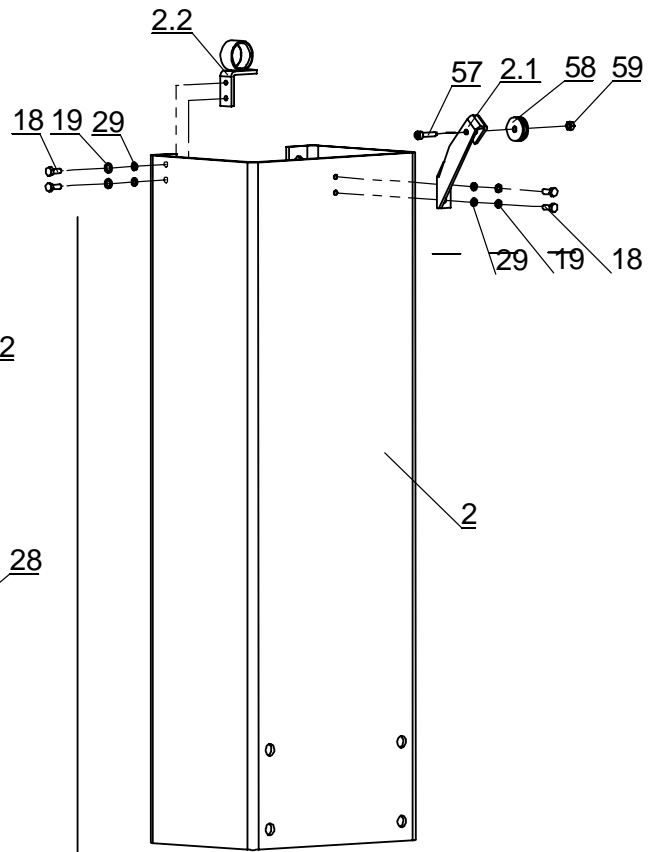

Figure 4

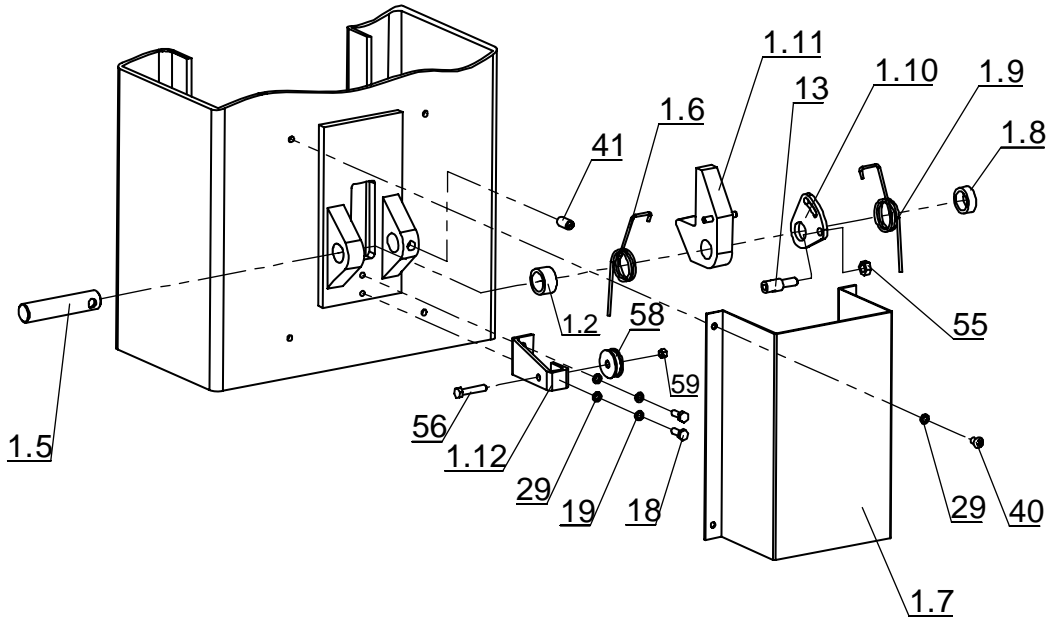

Figure 5

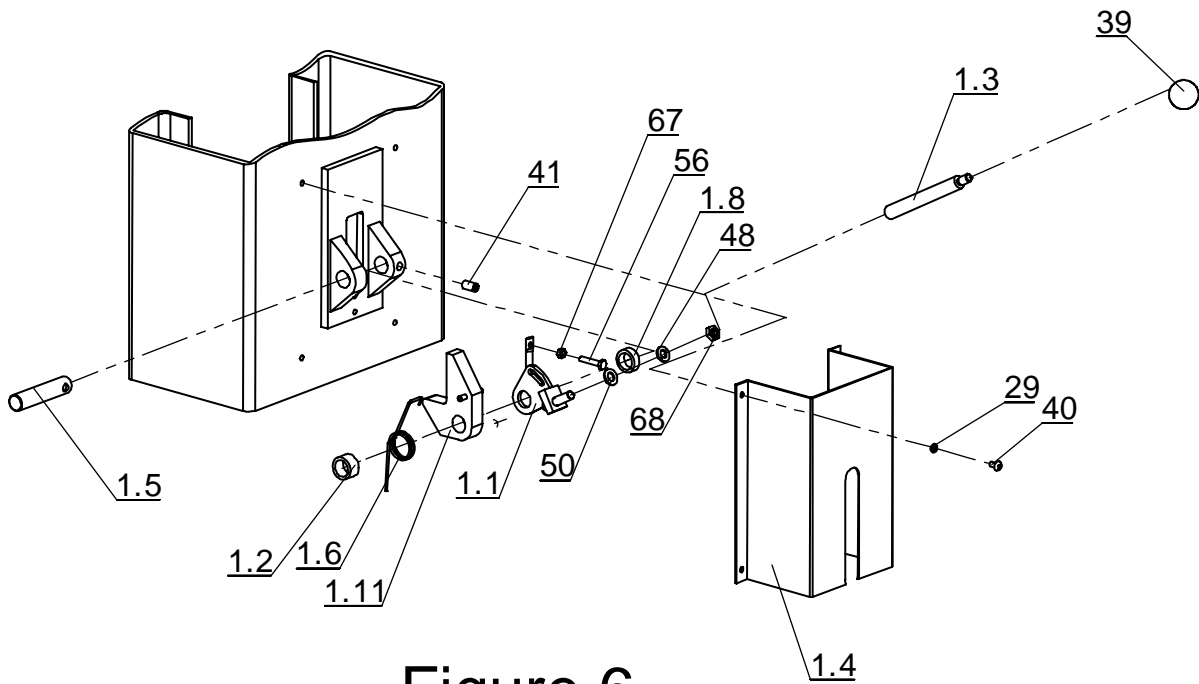

Figure 6

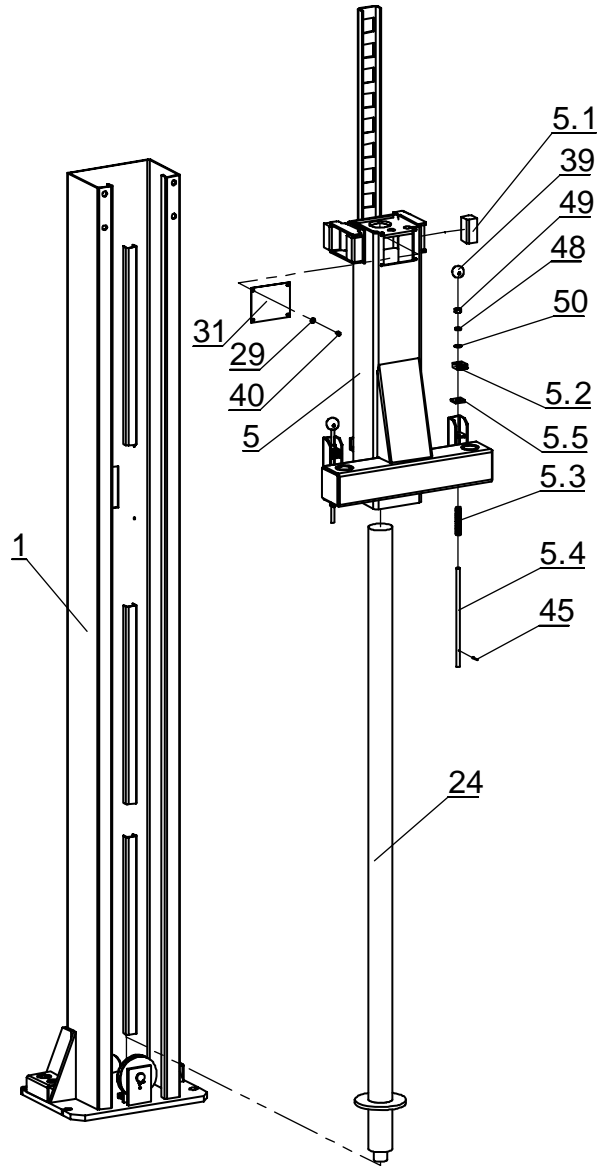

Figure 7

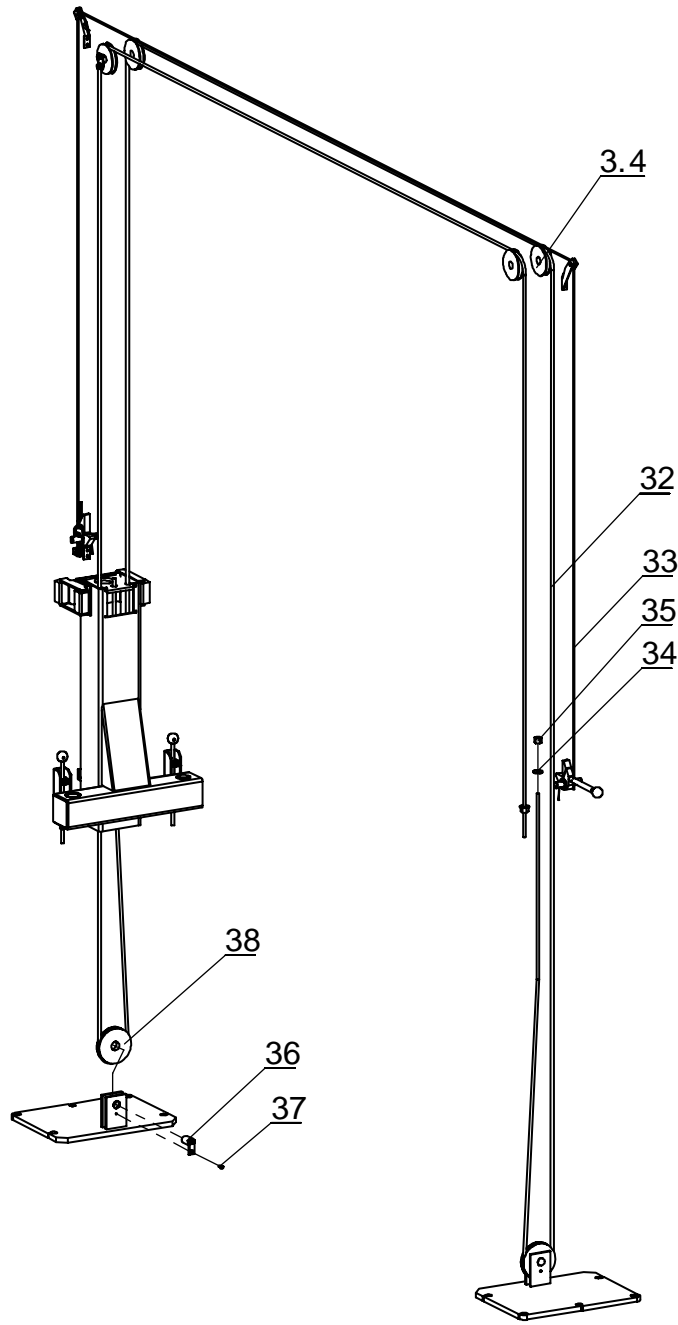

Figure 8

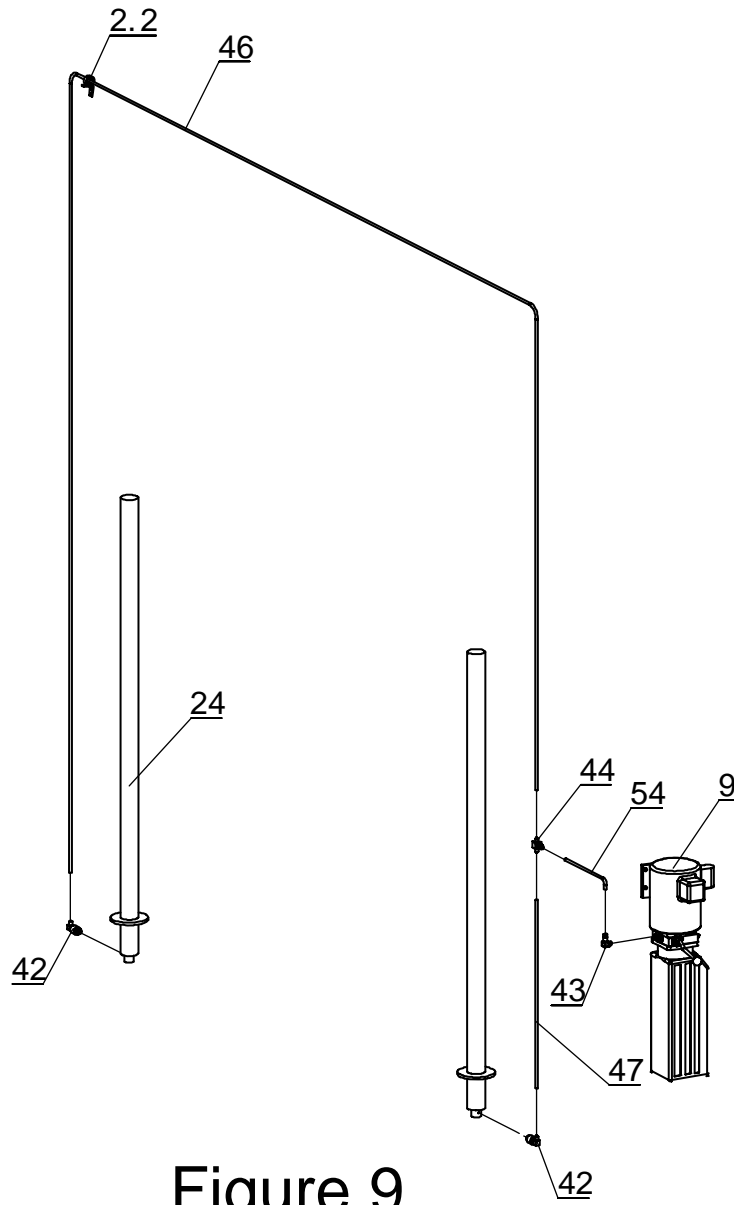

Figure 9

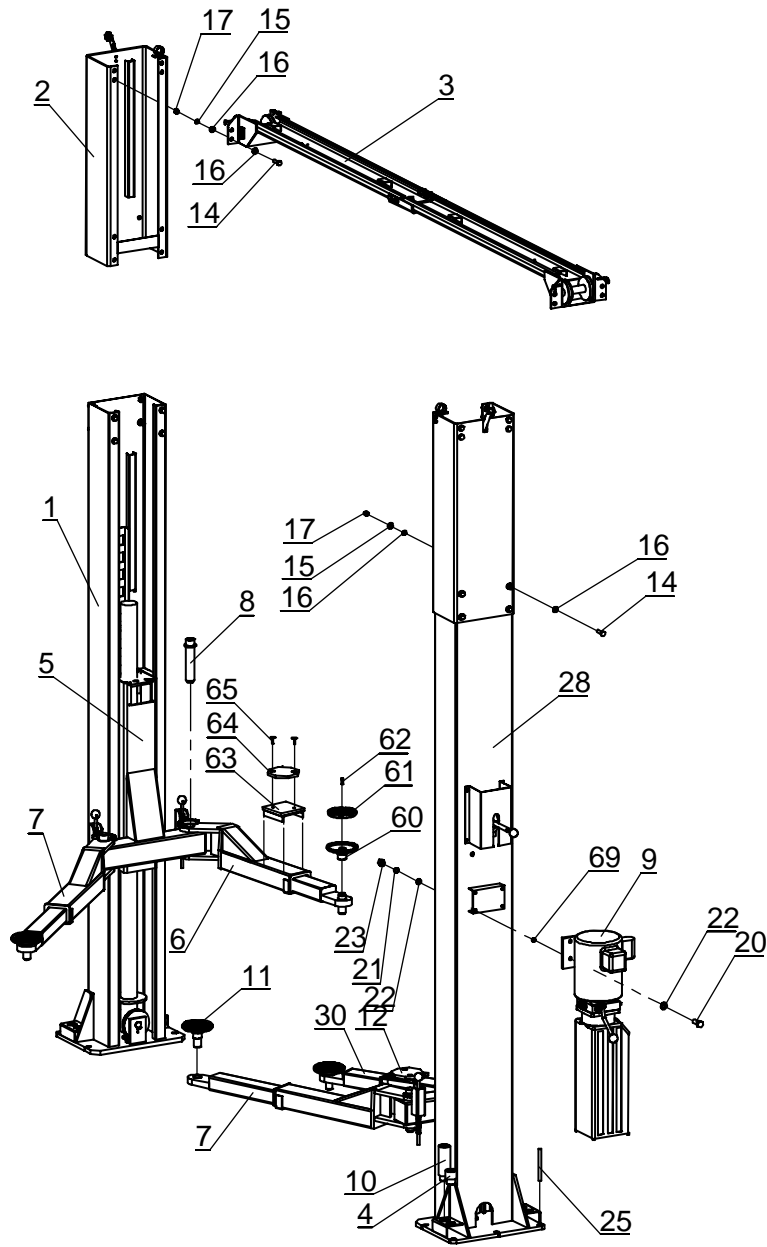

Figure 10

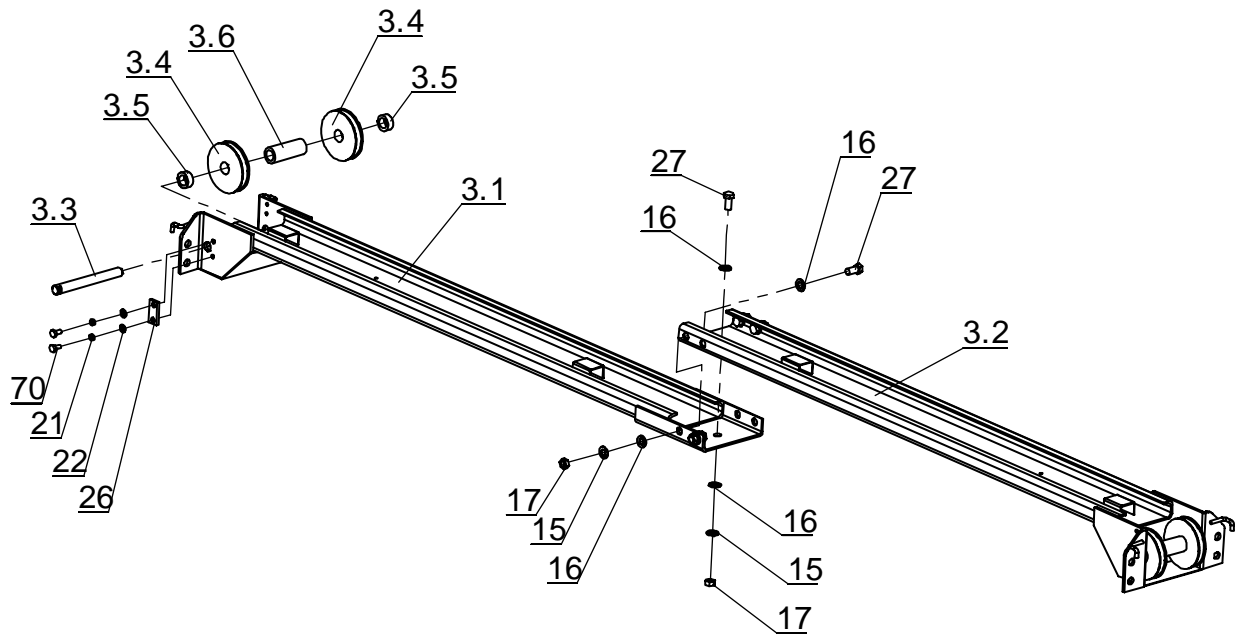

Figure 11

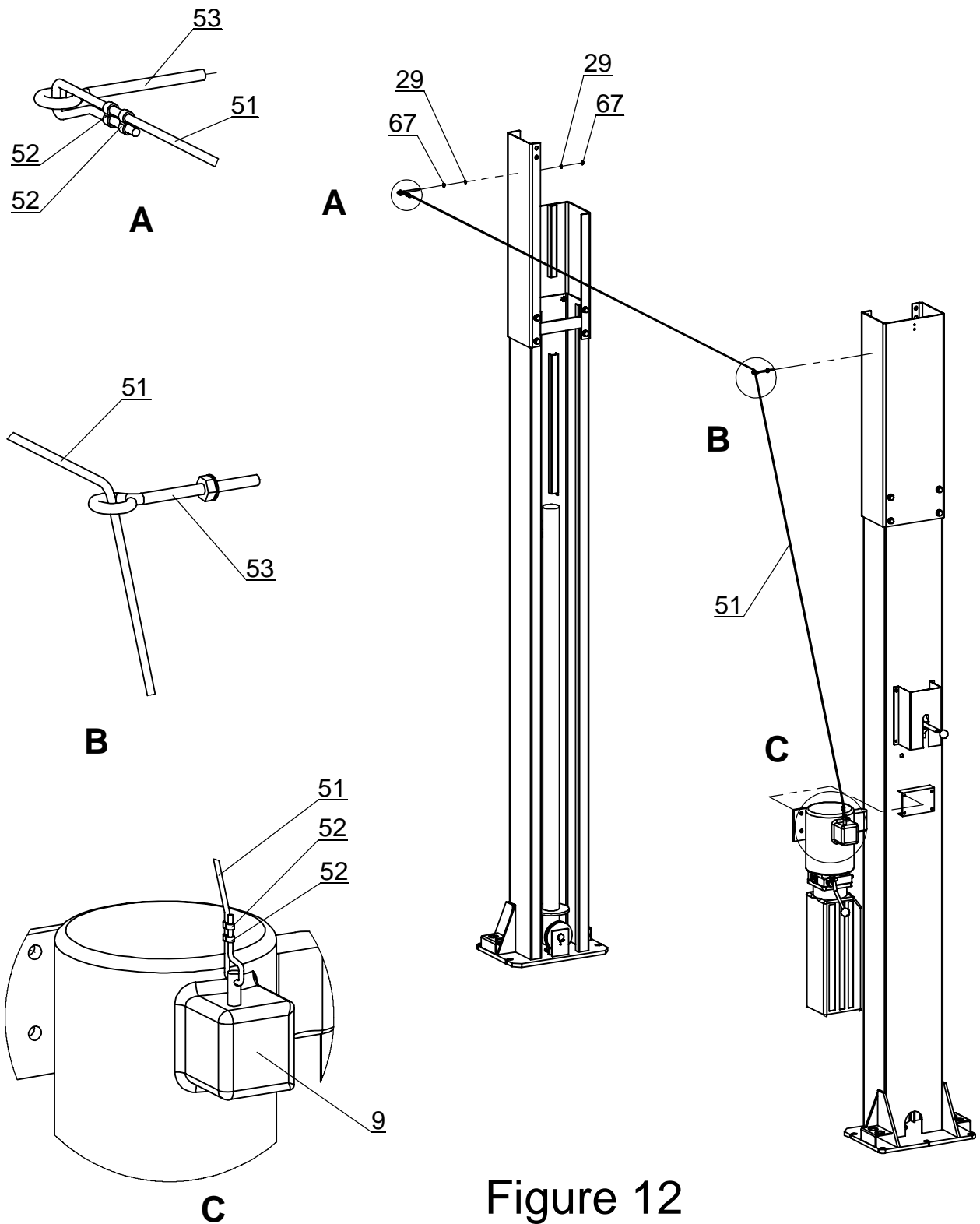

Figure 12

ITEM	DRAWING	DESCRIPTION	QTY
1	HPRO-1000	Column A, Slave Side	1
1.1	30500-5001(B)-26G1	Safety Cam Plate, Master Side	1
1.2	30500-5001(B)-07	Bushing A	2
1.3	30500-5001(B)-12	Safety Release Handle	1
1.4	30500-8000-01A	Cover A	1
1.5	30500-5001(B)-09	Latch Shaft	2
1.6	30500-5001(B)-10	Spring A	2
1.7	30500-8000-01B	Cover B	1
1.8	30500-5001(B)-24	Bushing B	2
1.9	30500-5001(B)-25G1	Spring B	1
1.10	30500-5001(B)-22	Safety Cam Plate, Slave Side	1
1.11	30500-5001(B)-21	Safety Latch	2
1.12	30500-8000-3-1	Cable Pulley Bracket B	1
2	HPRO-3000	Upright	2
2.1	30500-8000-2-1	Cable Pulley Bracket A	2
2.2	HPRO-3003	Hydraulic Hose Guide	2
3	HPRO-4000	Cross Beam Assembly	1
3.1	HPRO-4001	Overhead Cross Beam, Section A	1
3.2	HPRO-4002	Overhead Cross Beam, Section B	1
3.3	HPRO-4003	Top Cable Pulley Shaft	2
3.4	52006	4" Cable Pulley	4
3.5	HPRO-4004	Spacer A	4
3.6	HPRO-4005	Spacer B	2
4	30400-6014A	Short Truck Adapter A	4
5	HPRO-2000	Carriage	2
5.1	30400-5024	UHWB Sliding Bearing Block	16
5.2	30400-5014	Gear Rack	4
5.3	30400-5012-1	Spring	4
5.4	30400-5015	Gear Rack Shaft	4
5.5	30400-5017	Spacer	4
6	30400-7000-X	Front Arm A	1
7	30400-6000-X	Long Arm	2
8	30400-5005	Arm Pin	4
9	P3548	Power Unit	1
10	30400-6015A	Tall Truck Adapter B	4
11	30400-6005-1	Lifting Pad Assembly	4
12	30400-7013	Saddle Pad Assembly	2
13	30500-5001(B)-23	Threaded Shaft	1
14	B10-12x40	M12x40 Hex Bolt	24
15	B40-12	Ø12 Lock Washer	29
16	B42-12	Ø 12 Flat Washer	58

PRO 9D Two-Column Automotive Lift

17	B30-12	M12 Hex Nuts	29
18	B10-6x16	M6x16 Hex Bolt	14
19	B40-6	Ø 6 Lock Washer	14
20	B10-8x25	M8x25 Hex Bolt	4
21	B40-8	Ø 8 Lock Washer	8
22	B41-8	Ø 8 Flat Washer	12
23	B30-8	M8 Hex Nuts	4
24	YG11-9100	Hydraulic Cylinder	2
25	B14-3/4x140	3/4"x140 Anchor Bolt	10
26	NH4D-2005	Stop Non-rotator Bar	2
27	B10-12x25	M12x25 Hex Bolt	5
28	HPRO-1000A	Column B, Master Side	1
29	B41-6	Ø 6 Flat Washer	26
30	30400-7000-XDC	Front Arm B	1
31	HPRO-2008	Cover	2
32	HPRO-9000	Equalizing Cable	2
33	HPRO-9001	Safety Release Cable	1
34	B41-20	Ø 20 Flat Washer	4
35	B33-3/4-16	3/4"-16 Nylon Lock Washer	4
36	HPRO-1007	Cable Pulley Shaft	2
37	B24-6x12	M6x12 Bolt	2
38	52005	4.75" Cable Sheave	2
39	B84-10	M10x Ø 35 Knob	5
40	B23-6x8	M6x8 Screw	16
41	B22-10x16	M10x16 Hex Head Screw	2
42	HPRO-Y001	Pipe Fitting	2
43	30400-9053YZ	90 Degree Fitting	1
44	HPRO-Y002	T-Fitting	1
45	B51-3x26	Ø 3x26 Roll Pin	4
46	1WB-14	Hydraulic Hose A	1
47	1WB-22	Hydraulic Hose B	1
48	B40-10	Ø 10 Lock Washer	5
49	B30-10	M10 Hex Bolt	4
50	B41-10	Ø 10 Flat Washer	5
51	B86-1.5x5900	Shut-Off Cable	1
52	B87-1.5	Aluminum Clevis	4
53	B15-6x50	M6x50 Bolt	2
54	1WB-13JC	Hydraulic Hose C	1
55	30500-5001(B)-27	M8 Nut	1
56	B10-6x35	M6x35 Hex Bolt	2
57	B20-6x25	M6x25 Screw	2
58	30500-8000-2-2	Lock Release Cable Pulley	3

PRO 9D Two-Column Automotive Lift

59	B33-6	M6 Nylon Lock Nut	3
60	30400-6005-2	Lift Pad Weldment	4
61	PV-6003	Rubber Pad	4
62	B20-6x20	M6x20 Pad Screw	4
63	30400-7013A	Saddle Weldment	2
64	52200-3	Rubber Pad For Sadder	2
65	B29-6x16	M6x16 Screw	4
67	B30-6	M6 Nut	5
68	B36-10	NUT M10	1
69	30400-1999	WASHER	4
70	B10-8x16	M8x16 Hex Bolt	4