

LAUNCH TECH USA, INC.

LAUNCH

Installation, Operation & Maintenance Manual

Two Post Surface Mounted Lifts

TLT210-A

10,000 lbs. Capacity
2,500 lbs. per Arm

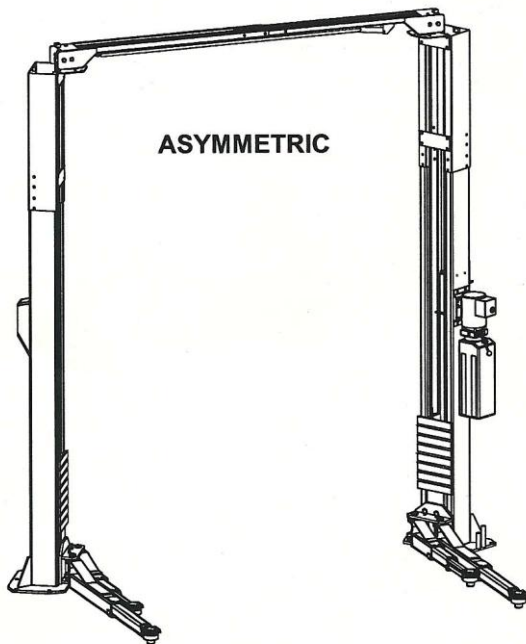

TLT210-AS

10,000 lbs. Capacity
2,500 lbs. per Arm

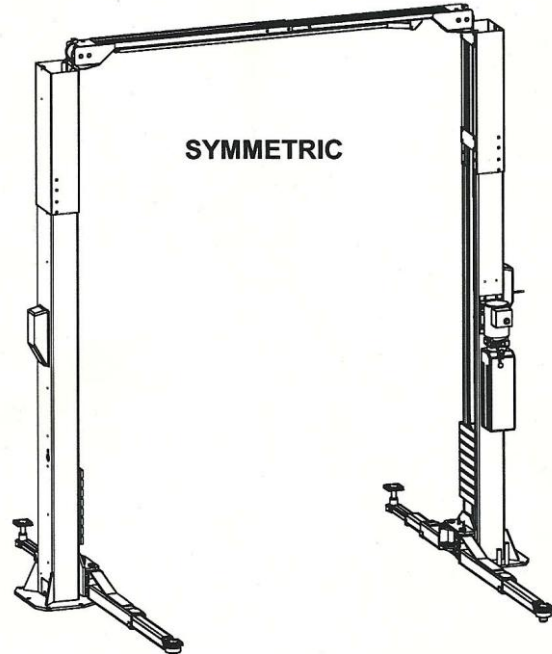

1820 S Milliken Ave. Ontario, California 91761
Tel: 562 463-1580 Fax: 562 463-1590 www.launchtechusa.com

IMPORTANT: READ THIS MANUAL COMPLETELY BEFORE
INSTALLING OR OPERATING LIFT

Launch Models TLT210-A and TLT210-AS

General Specifications

See Figure 1	TLT210-A	TLT210-AS
A. Lifting Height	76.4" (1940mm)	76.4" (1940mm)
B. Column Height	148.8" (3780mm)	148.8" (3780mm)
C. Cylinder Full Height	145.2" (3688mm)	145.2" (3688mm)
D. Total Width	137.9" (3502mm)	136.6" (3470mm)
E. Drive-Thru Clearance	92" (2338mm)	98.4" (2500mm)
F. Floor to Overhead Switch	145" (3683mm)	145" (3688mm)
G. Front Arm Reach (min / max)	23.6" 9600mm) / 43.5" (1105mm)	23.6" 9600mm) / 43.5" (1105mm)
H. Rear Arm Reach (min / max)	38.6" (980mm) / 61.8" (1570mm)	38.6" (980mm) / 61.8" (1570mm)
I. Screw Pad Height	4" (101mm) to 7.5" (190mm)	4" (101mm) to 7.5" (190mm)
J. Inside Column Width	101.9" (2588mm)	110.2" (2800mm)
Motor	2 HP	2 HP
Voltage	208-230Volt/Single Phase	208-230Volt/Single Phase
Rise Speed	54 Seconds	54 Seconds
Max. Load Per Arm	2500 Lbs.	2500 Lbs.
Ceiling Height Required	149.5" (3797mm)	149.5" (3797mm)
Narrow Bay Setting	Deduct 5.9" (149mm)	Deduct 5.9" (149mm)

- Rise height measured with footpads in the highest position.
- Lift capacity rating is based on loads equally distributed on all four arms.
- Lifting and lowering speeds may vary depending on the weight of the vehicle

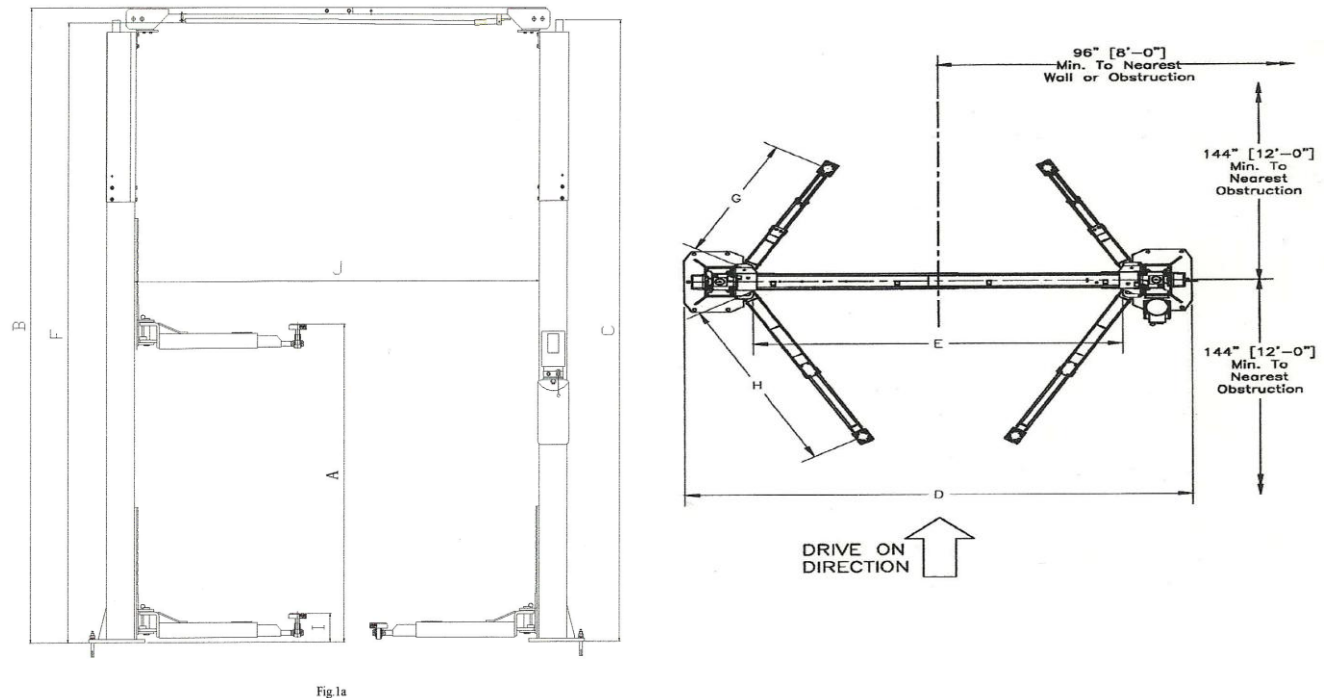

Figure 1-General Specifications and Service Bay Layout

Launch Models TLT210-A and TLT210-AS

VERTICAL CLEARANCE

Check the height of the area where the lift is to be installed. Clearance should be based on the full raised height of the lift.

WARNING! Failure by purchaser to provide adequate clearance could result in unsatisfactory lift performance, property damage, or personal injury.

FLOORING

Be certain you have the proper concrete floor to properly handle the loaded lift. Floor should be in generally good condition with no large cracks, spalling or deterioration.

****Minimum requirements for concrete are 4 inches minimum depth, with steel reinforcement, 3500 psi, cured for 28 days per local commercial practice.** Floor should be level within 3/8 inch over the installation area. No anchors should be installed within 8 inches of any crack, edge, or expansion joint. If these conditions cannot be met, a pad may be poured to accommodate the lift. Check with local building inspectors' and permits office for any special instructions or approvals required for your installation.

WARNING! Failure by purchaser to provide the recommended mounting surface could result in unsatisfactory lift performance, property damage, or personal injury.

LOCATION

This lift has been evaluated for indoor use only with an operating ambient temp. range of 5 - 40°C (41-104°F)

ELECTRICAL REQUIREMENTS

For lift installation and operation for single phase units, it is necessary to have a dedicated circuit with a double pole 25 amp circuit breaker or time delay fuse. All electrical connections should be performed by a licensed electrician.

SAFETY NOTICES AND DECALS

For your safety, and the safety of others, read and understand all of the safety notices and decals included here.

READ ENTIRE MANUAL BEFORE ASSEMBLING, INSTALLING, OPERATING, OR SERVICING THIS EQUIPMENT.

PROPER MAINTENANCE AND INSPECTION IS NECESSARY

**FOR SAFE OPERATION
DO NOT OPERATE A DAMAGED LIFT**

Safety decals similar to those shown here are found on a properly installed lift. Be sure that all safety decals have been correctly installed on the Power Unit reservoir. Verify that all authorized operators know the location of these decals and fully understand their meaning. Replace worn, faded, or damaged decals promptly.

WARNING! Do not attempt to raise a vehicle on the lift until the lift has been correctly installed and adjusted as described in this manual.

Automotive Lift Institute, Inc
WL101 Series
Label Kit

NOTICE Read operating and safety manuals before using lift.	NOTICE Proper maintenance and inspection is necessary for safe operation.	<small>The messages and pictographs shown are generic in nature and are meant to generally represent hazards common to all automotive lifts regardless of specific style. Funding for the development and validation of these labels was provided by the Automotive Lift Institute, PO Box 85 Cortland, NY 13045. Replacement label sets may be obtained from the original lift manufacturer and ALI's member companies. They are protected by copyright. www.autlift.org © 2009 by ALI, Inc. ALI/PL101a</small>	
NOTICE Do not operate a damaged lift.	<small>The messages and pictographs shown are generic in nature and are meant to generally represent hazards common to all automotive lifts regardless of specific style. Funding for the development and validation of these labels was provided by the Automotive Lift Institute, PO Box 85 Cortland, NY 13045. Replacement label sets may be obtained from the original lift manufacturer and ALI's member companies. They are protected by copyright. www.autlift.org © 2009 by ALI, Inc. ALI/PL101b</small>		
CAUTION Lift to be used by trained operator only.	CAUTION Authorized personnel only in lift area.	WARNING Clear area if vehicle is in danger of falling.	WARNING Position vehicle with center of gravity midway between adapters.
CAUTION Use vehicle manufacturer's lift points.	CAUTION Always use safety stands when removing or installing heavy components.	WARNING Remain clear of lift when raising or lowering vehicle.	WARNING Avoid excessive rocking of vehicle while on lift.
CAUTION Use height extenders when necessary to ensure good contact.	CAUTION Auxiliary adapters may reduce load capacity.	WARNING Do not override self-closing lift controls.	WARNING Keep feet clear of lift while lowering.

Launch Models TLT210-A and TLT210-AS

RECEIVING

The shipment should be thoroughly inspected as soon as it is received. The signed bill of lading is acknowledgement by the carrier of receipt in good condition of shipment covered by our invoice.

If any of the goods called for on your bill of lading are shorted or damaged, do not accept them until the carrier makes a notation on the freight bill of the missing or damaged goods. Do this for your own protection.

Contact Launch Lift immediately if any hidden loss or damage is discovered after receipt.

IT IS DIFFICULT TO COLLECT FOR LOSS OR DAMAGE AFTER YOU HAVE GIVEN THE CARRIER A CLEAR RECEIPT.

File your claim with the freight company promptly.

Support your claim with copies of the bill of lading, freight bill, and photographs.

Major Component Packing List

Qty.	Description
1	Power Side Column
1	Idler Side Column
2	Overhead Beams
2	Column Extensions
2	Rear Arm Assemblies
2	Front Arm Assemblies
2	Cable Assemblies
1	Hardware Box
1	Hydraulic Hose Kit
2	Lock Covers
1	Hydraulic Power Unit
1	Document Packet
4	Foot Pad Extensions

INSTALLATION IMPORTANT: Always wear safety glasses while installing lift.

SUGGESTED TOOLS (Minimum Required)

Tape measure, 16ft
Chalk line
4ft level
10" adjustable wrench
Metric open end wrenches 10mm, 13mm, 14mm, 15mm, 17mm, 18mm, 19mm and 24mm
Needle Nose pliers
Snap Ring pliers
Screw Drivers (Flat and Phillips)
Hammer drill with 3/4" diameter carbide tipped bits
2 lb. hammer
Torque wrench: 150 foot pounds minimum with 1 1/8" socket
12 ft. Step ladder
Anti-Seize lubricant (for arm pins and foot pad screw threads and stop rings)
Hydraulic line sealant (<i>Do not use Teflon tape...this can cause leaking.</i>)

LAYOUT

* Layout the service bay according to the architect's plans or owners instructions (*see Fig 1*). Failure to install in this orientation can result in personal and property damage. Be certain that the proper conditions exist, see page 3.

* Assemble column extension to each column using (12 sets) M12 x 35 Hex bolts, flat washers, lock washers and nuts. Repeat for opposite column and extension. Refer to Fig. 2 below.

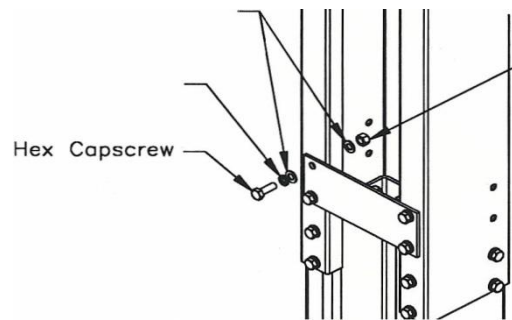

Figure 2

Launch Models TLT210-A and TLT210-AS

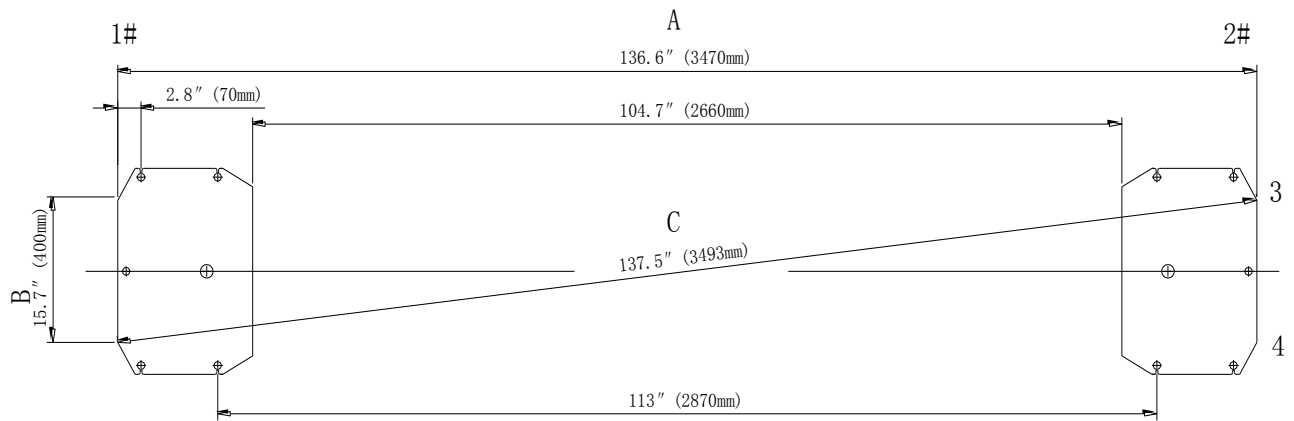

Figure 3 TLT210-AS

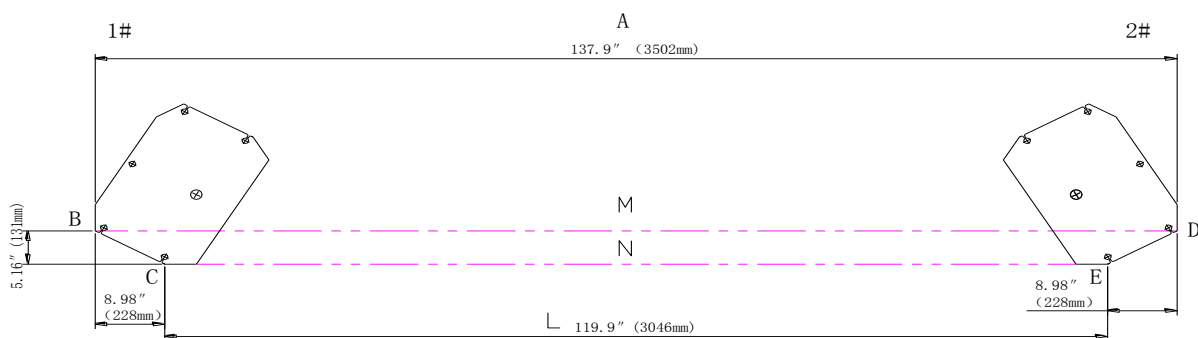

Figure 4 TLT210-A

Base plate layout

As shown in Figure 3 (symmetric installation).

- With total width (A) as the basis, draw two parallel lines (#1 and #2) on the concrete slab.
- Determine the power side column location on any chalk line, and mark the total width (B) of the base plate. Mark the points 3 and 4.
- Starting from point 3, draw one diagonal line (C) to the point 5 forming a triangle. In this way, the #1 and #2 lines can determine the location of the two columns.

For asymmetric installation see Figure 4.

- With total width (A) as the basis, draw two parallel lines (#1 and #2) on the concrete slab.
- Mark any point on line #1 as point B. Take B as a base point, then move downward with 131mm and rightward with 228mm to get point C. Take B as a base point, and then draw a line M with same length of A, which is perpendicular to B to get point. Take as a base point, and then draw a line N with same

length of L, which is parallel to M to get point E. The column relative position could be located by ABCDE.



Notes:

- ◆ **All the dimensions are based on the external border of the base plate.**
- ◆ **The lift layout is very important. If not done properly, problems may occur during the final assembly and operation.**

Install the power side column

First connect and assemble the column extension with the power side column, and then raise the power side column upright to the chalked location. Align the base plate of column with the chalk line layout. Using the baseplate as a template, drill holes into the concrete slab and use the five concrete anchor bolts to attach the column to the floor. During the drilling process, do not allow any movement of the column from the chalk line.

Launch Models TLT210-A and TLT210-AS

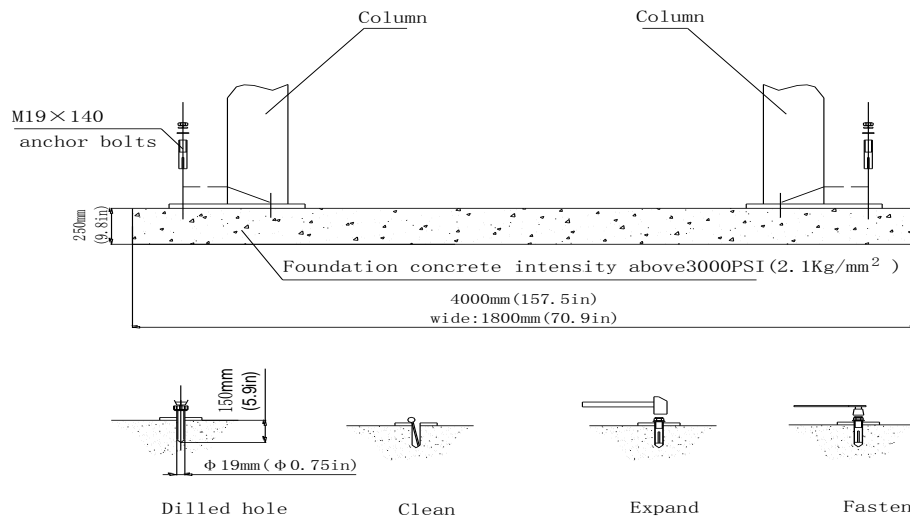

Figure 5

Anchoring

- The anchor bolts must be installed at least 8" away from any crack, edge, or expansion joint.
- Use a concrete hammer drill with a 3/4 inch carbide bit. The tip diameter should conform to ANSI Standard B94.12-1988 (.775 to .787). Do not use any excessively worn bits or bits which have been incorrectly sharpened. A core bit may be necessary if obstructions such as steel rebar or rocks are encountered. **Never substitute with a shorter or incorrect diameter anchor bolt.**
- Recheck overall width dimension, fig. 3 or fig. 4. Drill the anchor holes using the baseplate as a template. Drill through the floor if possible or at least 6 inches minimum.
- Vacuum the dust from the hole to ensure proper anchor bolt holding power.
- Shim column to plumb using the shims provided. Do not shim more than 1/2 inch at any given point. Use a 24 inch or larger level in length to plumb the columns.
- Assemble the washer and nut to anchor with the nut just below the impact section of the bolt.
- Drive the anchor bolt into the hole until the nut and washer contact the baseplate.
- Tighten the anchors and recheck the column for plumb. Re-shim if necessary. Using a torque wrench only, tighten to 150 foot lbs. **Do not use an impact gun to tighten the anchor bolts.**

Installing the overhead beam

After attaching the column extension to the idler column, position the idler column at the designated chalk location. Lift the overhead beam to its highest position and use the fasteners to attach it to the columns (as shown in Fig. 6). When installing the overhead beam, ensure the microswitch support adjacent to the power side column is positioned at the power side column location. Route the microswitch cord through the end of the overhead beam and down the outside of the column as shown in Fig. 11.

Note: Since the idler column is not secured to the floor by the bolts at this stage, be careful to not move the idle column as it could tilt over.

Launch Models TLT210-A and TLT210-AS

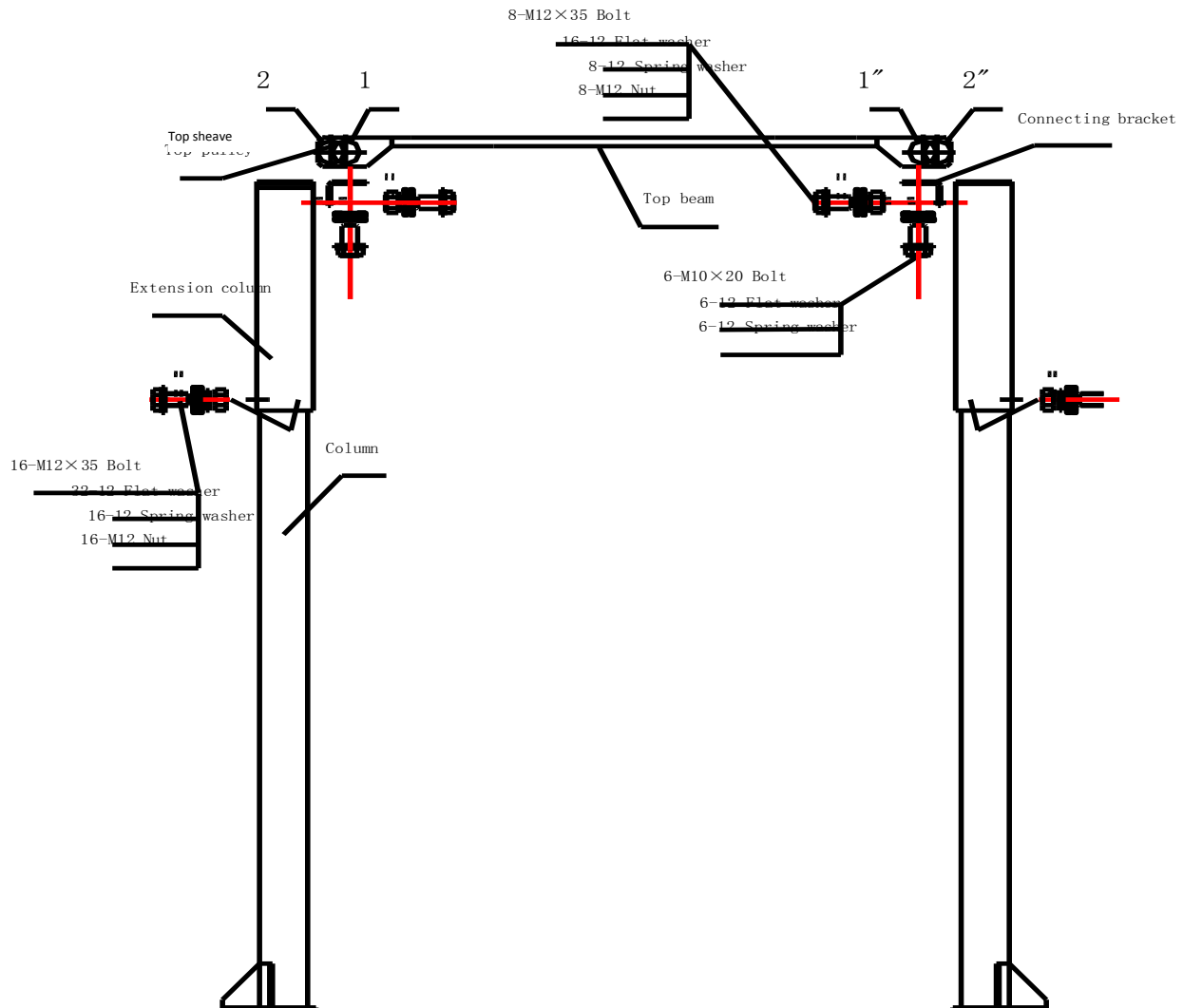

Figure 6

Finish installing the idler column

Drill holes and install the idler column following the same procedures as outlined for the power side column.

Install and adjust the steel cables

- Raise the two carriages to the safety locking position (make sure that the safety locks on each column are fully engaged before attempting to install cables), and the two carriages are in equal position from the floor (same height). Install the two steel cables as shown in Fig. 7.

- Adjust the tension of cables through the adjustment nuts on each end of steel cable. The steel cables should be tight in equal tension. Each steel cable should be in the sheave when adjusting tightly, otherwise the steel cable will be damaged.

⚠ Note: Before operating the lift check the steel cables and verify they are not intersected and are properly installed. Make sure that the steel cables are still on the sheaves.

Launch Models TLT210-A and TLT210-AS

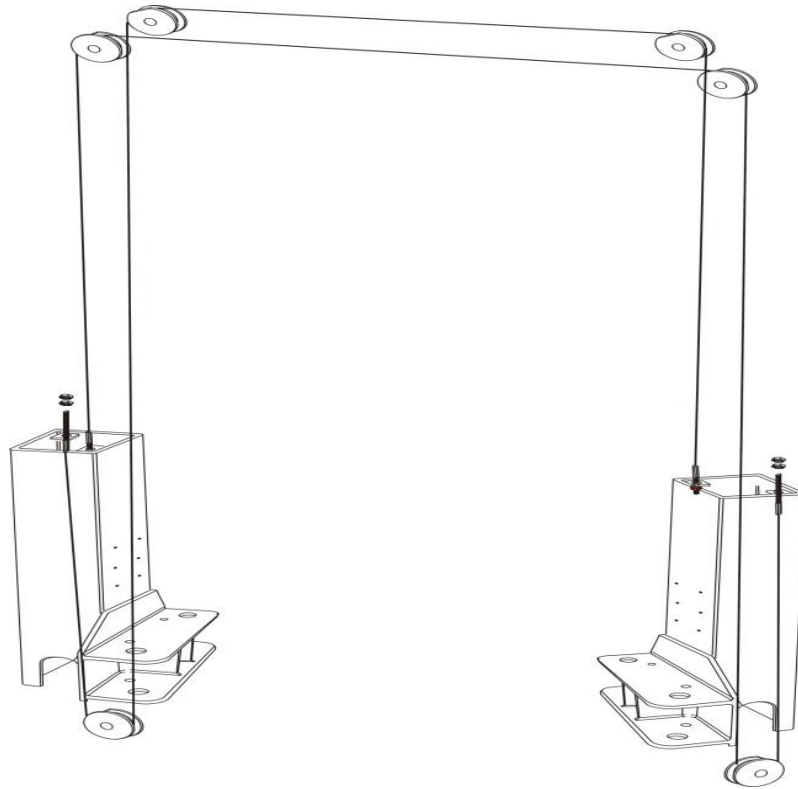

Figure 7

Key points for assembly: the two steel cables shall be adjusted to equal tension in order to verify the simultaneous movement of the two carriages.

Install the power unit

- Use 5/16x18 bolts and washers (see fig. 8) to secure the power unit. After the securing of the power unit. Fill the reservoir with hydraulic oil (oil capacity of 10L). Operate carefully to avoid dust and other pollutants mixing with the hydraulic oil.

Connecting the power supply

* Dismantle the sealed cover of the electrical box on the power unit and do the wiring according to the circuit diagram. A power supply switch is required to be installed near the lift for rapidly disconnecting the power supply during maintenance or in case of emergency. Motor damage caused by improper wiring is not warranted. Verify that the oil tank is full; do not operate if there is no oil. After pressing the up button, if the motor doesn't run or abnormal noise or heat occurs, the power unit shall be

immediately stopped to check for proper electrical connections.

* Connect the microswitch cord as shown in Fig. 11 and Fig. 12.

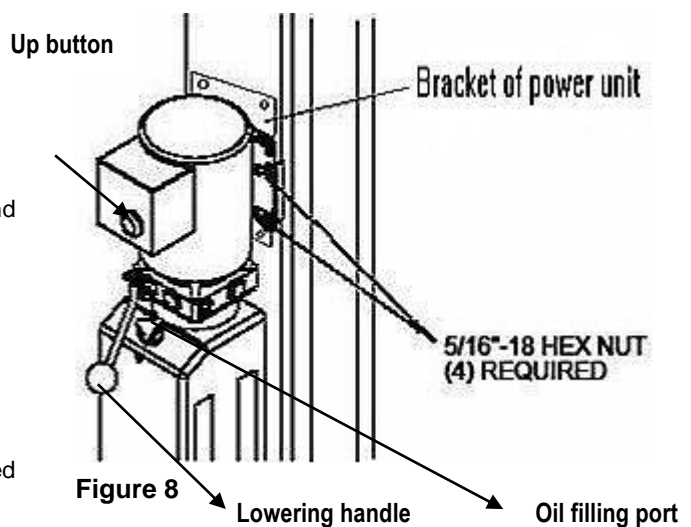

Figure 8



Note: Do not install this product outdoors.

Motors and electrical controls are not sealed against weather or moisture. Damage or electrical shock may occur if installed unprotected outdoors.

Launch Models TLT210-A and TLT210-AS

Install the Lock Release Cable

Raise lift to a lock position but do not set onto lock. Pull and release power column lock release handle and watch the idler column lock. Adjust cable tension by removing slack in the cable and retightening the cable clamp at the power side.

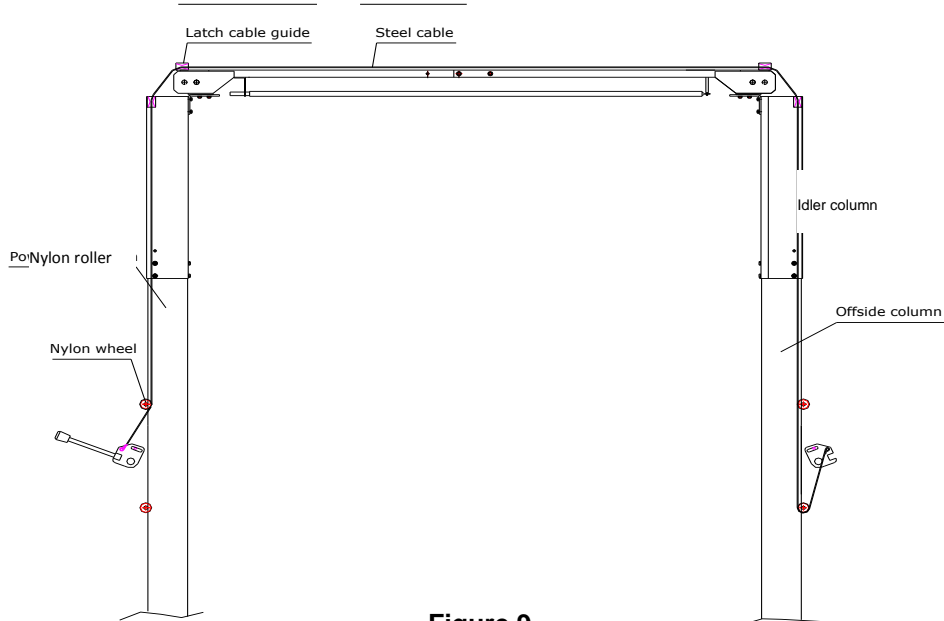

Figure 9

Connect the hydraulic lines

Install all hydraulic lines and fittings as shown in fig.10. Clean all piping and hose threads and inspect for damage. Use oil resistant pipe sealant on all the threads and tighten properly. **Do not use Teflon tape.** It is the installers' responsibility to insure the system is leak free.

Improperly installed hydraulic fittings are not covered under warranty



Note: If the hose shall be installed through the column, ensure that the hose passage will not interfere with any moving parts.

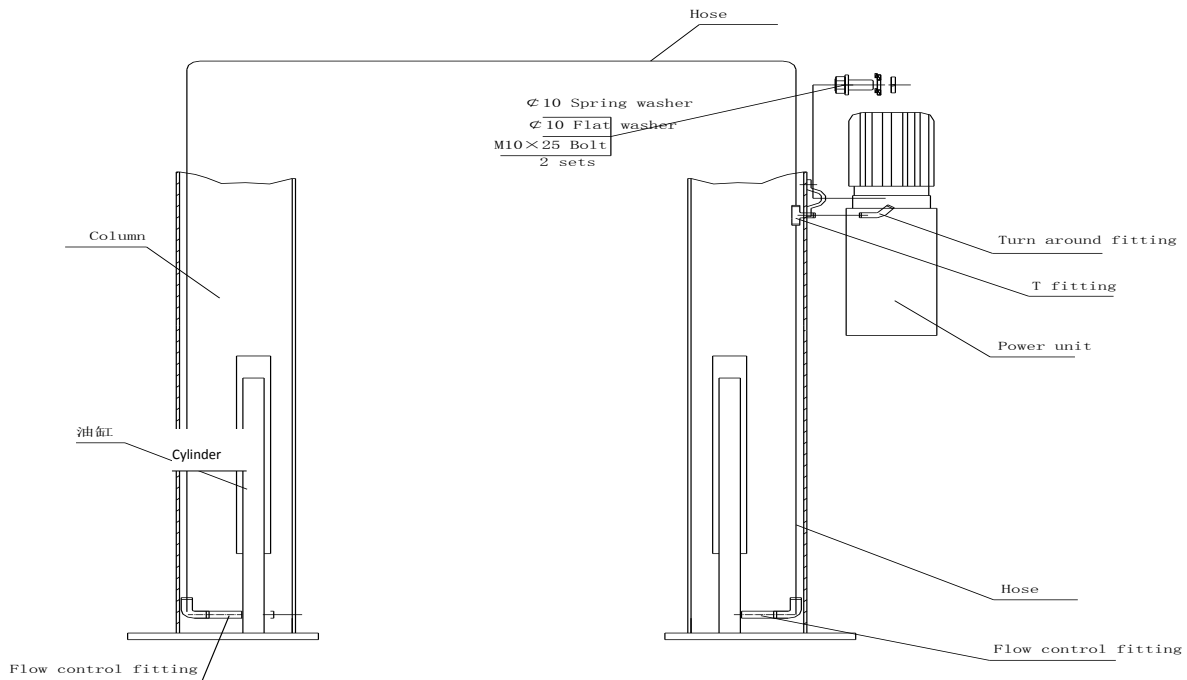

Figure

Launch Models TLT210-A and TLT210-AS

Proper installation of the overhead microswitch electrical cord

It is very important to keep proper clearance between microswitch electrical cord and the steel cable. Use the provided plastic ties to connect the electrical cord and hose together to avoid any possible damage caused by interference between the electrical cord and the steel cable.

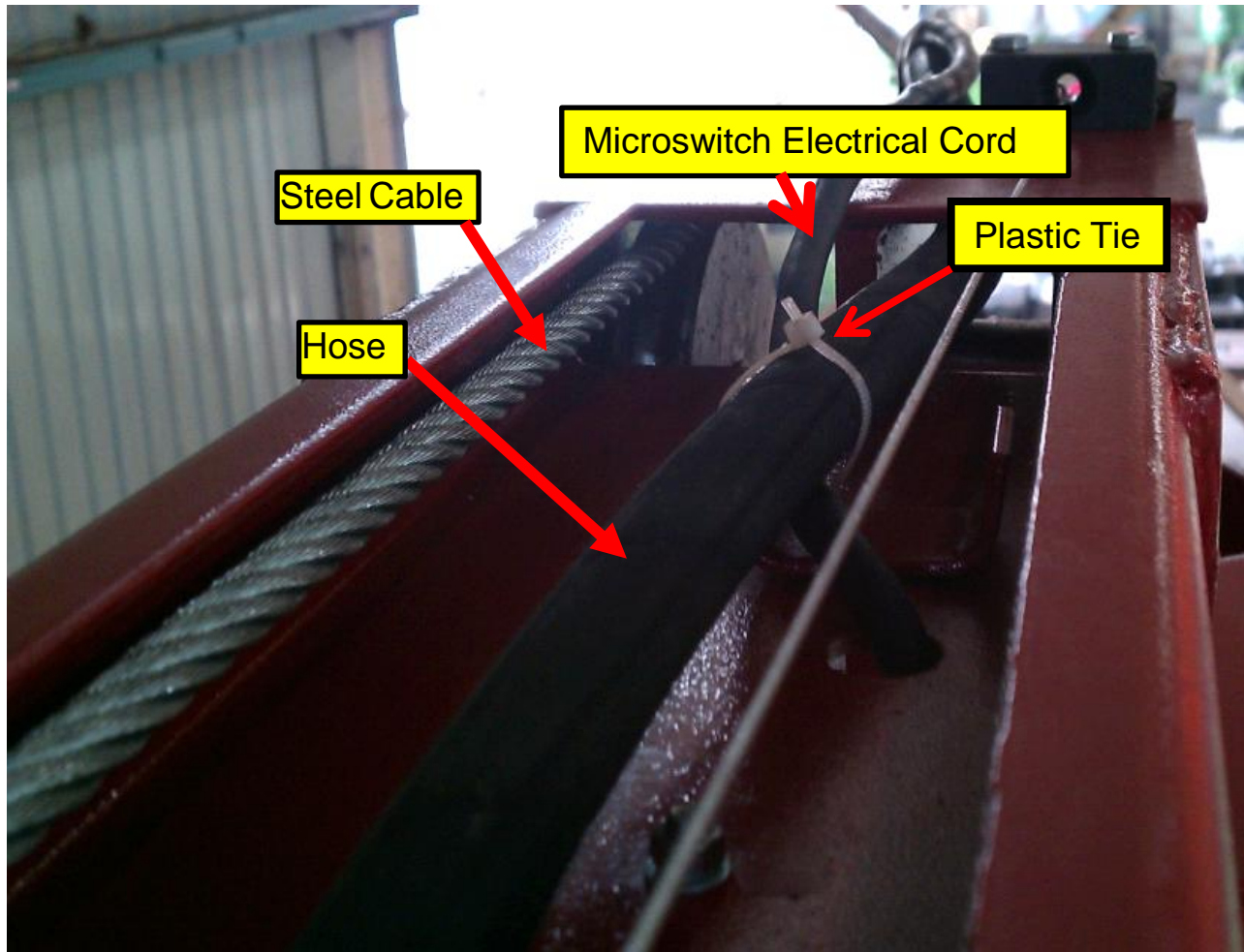

Figure 11

Wiring Diagram

EACH LIFT SHOULD HAVE A DEDICATED CIRCUIT WITH A DOUBLE POLE (THREE POLE FOR 440-480V) BREAKER OR TIME DELAY FUSE SIZED ACCORDING TO THE FOLLOWING CHART

	1 ϕ 208-240V	3 ϕ 208V	3 ϕ 220-240V	3 ϕ 440-480V
2Hp	25amp	15amp	15amp	5amp

* WIRING MUST COMPLY WITH ALL LOCAL ELECTRICAL CODES *

FOR SINGLE PHASE

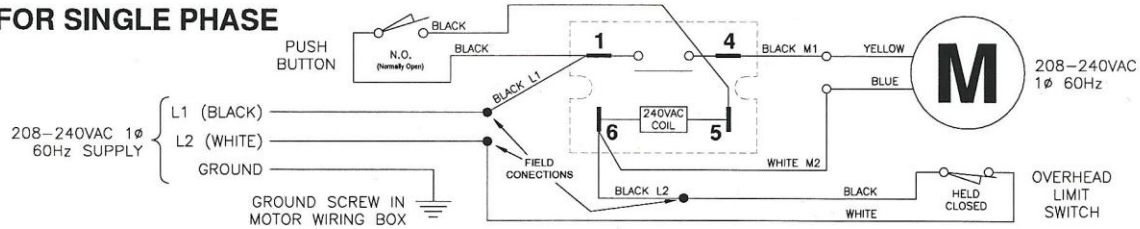

FOR THREE PHASE

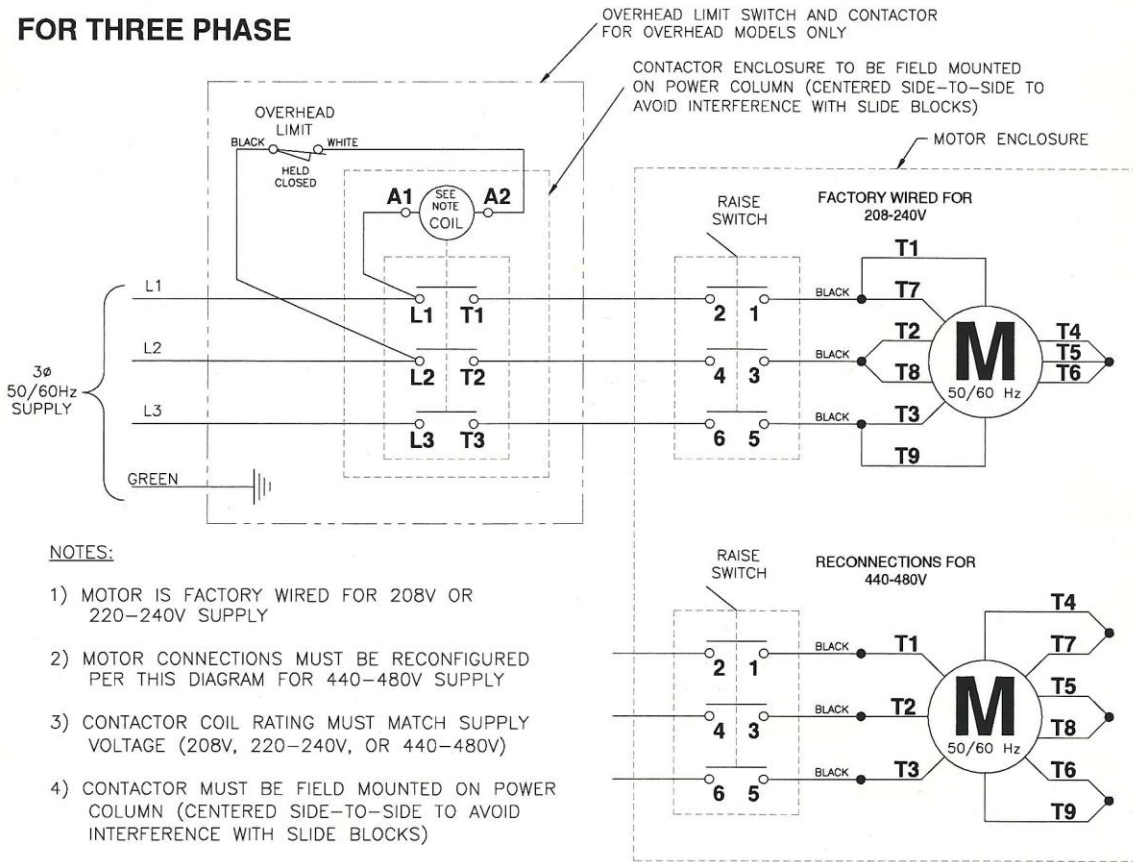

NOTES:

- 1) MOTOR IS FACTORY WIRED FOR 208V OR 220-240V SUPPLY
- 2) MOTOR CONNECTIONS MUST BE RECONFIGURED PER THIS DIAGRAM FOR 440-480V SUPPLY
- 3) CONTACTOR COIL RATING MUST MATCH SUPPLY VOLTAGE (208V, 220-240V, OR 440-480V)
- 4) CONTACTOR MUST BE FIELD MOUNTED ON POWER COLUMN (CENTERED SIDE-TO-SIDE TO AVOID INTERFERENCE WITH SLIDE BLOCKS)
- 5) MOTOR ROTATION IS COUNTER CLOCKWISE FROM TOP OF MOTOR

Figure 12

Launch Models TLT210-A and TLT210-A

OWNER/OPERATOR CHECKLIST

Demonstrate the operation of the lift to the owner/operator and review the correct and safe lifting procedures using the provided *Lifting It Right* booklet as a guide.

Complete the installation and review the terms of the warranty registration card and return the card to:

Launch Tech USA Inc.
1820 S. Milliken Ave.
Ontario, CA. 91761
1-562-463-1580

OPERATION PROCEDURE

SAFETY NOTICES AND DECALS

This product is furnished with graphic safety warning labels, which are reproduced on page 2. Do not remove or deface these warning labels, or allow them to be removed or defaced. For your safety, and the safety of others, read and understand all of the safety notices and decals included.

OWNER/EMPLOYER RESPONSIBILITIES

This lift has been designed and constructed according to ANSI/All ALCTV-2006 standard. The standard applies to lift manufactures, as well as to owners and employers. The owner/employer's responsibilities as prescribed by ANSI/All ALOIM-2000, are summarized below. For exact wording refer to the actual standard provided with this manual in the literature package

The Owner/Employer shall insure that lift operators are qualified and that they are trained in the safe use and operation of the lift using the manufacturer's operating instructions; ALI/SM 93 -1, *ALI Lifting it Right* safety manual; ALI/ST- 90 All Safety Tips card; ANSI/ALI ALOIM-2000, *American National Standard for Automotive Lifts- Safety Requirements for Operation, Inspection and Maintenance*; ALI/WL Series, ALI Uniform Warning Label Decals/Placards; and in case of frame engaging lifts, ALI/LP-GUIDE, *Vehicle Lifting Points/Quick Reference Guide for Frame Engaging Lifts*.

The Owner/Employer shall establish procedures to periodically inspect the lift in accordance with the lift manufacturer's instructions or ANSI/All ALOIM-2000, *American National Standard for Automotive Lifts-Safety Requirements for Operation, Inspection and Maintenance*; and the employer shall insure that the lift inspectors

are qualified and that they are adequately trained in the inspection of the lift.

The Owner/Employer shall establish procedures to periodically maintain the lift in accordance with the lift manufacturer's instructions or ANSI/ALOIM-2000, *American National Standard for Automotive Lifts-Safety Requirements for Operation, Inspection and Maintenance*; and the employer shall insure that the lift maintenance personnel are qualified and that they are adequately trained in the maintenance of the lift.

The Owner/Employer shall maintain the periodic inspection and maintenance records recommended by the manufacturer or ANSI/All ALOIM-2000, *American National Standard for Automotive Lifts-Safety Requirements for Operation, Inspection and Maintenance*.

The Owner/Employer shall display the lift manufacturer's operating instructions; ALI/SM 93 -1, *ALI Lifting it Right safety manual*; ALI/ST-90 ALI Safety Tips card; ANSI/All ALOIM-2000, *American National Standard for Automotive Lifts- Safety Requirements for Operation, Inspection and Maintenance*; and in the case of frame engaging lift, ALI/LP-GUIDE, *Vehicle Lifting Points/Quick Reference Guide for Frame Engaging Lifts*; in a conspicuous location in the lift area convenient to the operator.

IMPORTANT SAFETY INSTRUCTIONS

When using your garage equipment, basic safety precautions should always be followed, including the following:

1. Read all instructions.
2. Care must be taken as burns can occur from touching hot parts.
3. To reduce the risk of fire, do not operate equipment in the vicinity of open containers of flammable liquids (gasoline).
4. Keep hair, loose clothing, fingers, and all parts of body away from moving parts.
5. Use only as described in this manual. Use only manufacturer's recommended attachments.
6. **ALWAYS WEAR SAFETY GLASSES.**
Everyday eyeglasses only have impact resistant lenses, they are not safety glasses.

SAVE THESE INSTRUCTIONS

Launch Models TLT210-A and TLT210-AS

LIFTING A VEHICLE

- Insure that the lifting arms are parked out to the full drive thru position.
- Center the vehicle between the columns in the service bay and position the vehicle's center of gravity midpoint between the columns.
- NOTE: the center of gravity is based on the weight distribution and is not the same as the center point of the vehicle.

DO NOT EXCEED 2500 POUNDS PER ARM.

DO NOT ATTEMPT TO LIFT A VEHICLE WITH ONLY ONE OR TWO ARMS, THIS IS UNSAFE AND WILL VOID THE WARRANTY.

INSURE THAT THE HIGHEST POINT ON THE VEHICLE WILL CONTACT THE OVERHEAD LIMIT SWITCH BAR.

DO NOT PLACE THE VEHICLE IN THE SERVICE BAY BACKWARDS.

REFER TO THE VEHICLE MANUFACTURERS SERVICE MANUAL, TECHNICAL BULLETINS, THE "VEHICLE LIFTING POINTS GUIDE" (ALIILP-GUIDE) THAT IS INCLUDED WITH THE LIFT OR OTHER PUBLICATIONS TO LOCATE THE RECOMMENDED LIFTING POINTS.

- Position the arms and adapters so all four pads contact the vehicle simultaneously.

The vehicle should remain level during lifting.

- Raise the lift until all four wheels are off the ground. Test the stability of the vehicle by attempting to rock the vehicle. Check the adapters for secure contact with the vehicle lift points. If the vehicle seems unstable, lower the vehicle and re-adjust the arms. After re-testing for stability, raise the vehicle 2-3 inches above the desired working height.
- Lower the vehicle until the safety latches on both columns engage. The vehicle should remain level when both latches are engaged. If one side engages and the other continues to descend, stop lowering the vehicle, raise it several inches, and try again to engage both latches.

Always lower lift into locks before entering the area beneath the vehicle.

Always use safety stands when removing or installing heavy components.

LOWERING A VEHICLE

- Insure that the area under the vehicle is clear of personnel, tools, toolboxes or service equipment.
- Raise the vehicle until both latches are free.
- Disengage the latches by pulling down and holding the lock release lever.
- Lower the vehicle by depressing the lowering valve handle.
- Continue to lower until the carriages stop against the base plate. Retract the extension arms, and move them away from the vehicle.

MAINTENANCE

To avoid personal injury, permit only qualified personnel to perform maintenance on this equipment. Maintenance personnel should follow lockout /tag out instructions per ANSI Z244.1.

The following maintenance points are suggested as the basis of a routine maintenance program. The actual maintenance program should be tailored to the installation. See *ANSI/All ALOIM* booklet for periodic inspection checklist and maintenance log sheet.

- If lift stops short of full rise or chatters, check fluid level and fill per installation instructions.
- Replace all Safety, Warning or Caution Labels if missing or damaged (**See installation instructions page 2**).

Daily

- Keep lift components clean.
- Check for loose or broken parts.
- Check hydraulic system for fluid leaks.
- Check adapters for damage or excessive wear. Replace as required with genuine Launch Lift parts.
- Check lock release activation. When properly adjusted, the idler column lock should rest firmly against the back of the column when engaged and pull clear of the column back when disengaged.

Weekly

- Check synchronizer cables and sheaves for wear. Replace as required with genuine Launch Lift parts.
- Check lock release cable adjustment per installation instructions.
- Check synchronizer cable tension per installation instructions. Adjust if necessary.

Monthly

- Torque all concrete anchor bolts to 150 ft-lbs.
- Check overhead shutoff switch. While raising lift, operate overhead shutoff bar. Power Unit motor should stop when bar is raised.
- Lubricate carriage slide tracks with heavy viscous grease. (Grease all (4) corners of both columns.)
- Visually inspect concrete floor for cracks and/or spalls within 12" of base plate.

If any problems are encountered, please contact Launch Tech USA, Inc.

Launch Models TLT210-A and TLT210-AS

List of lift components

This list is only used as information for the maintenance and repair. Launch Tech USA will not be liable for other uses.

In case of damages to the components, purchase can be made from the Launch Tech USA or its authorized distributors.

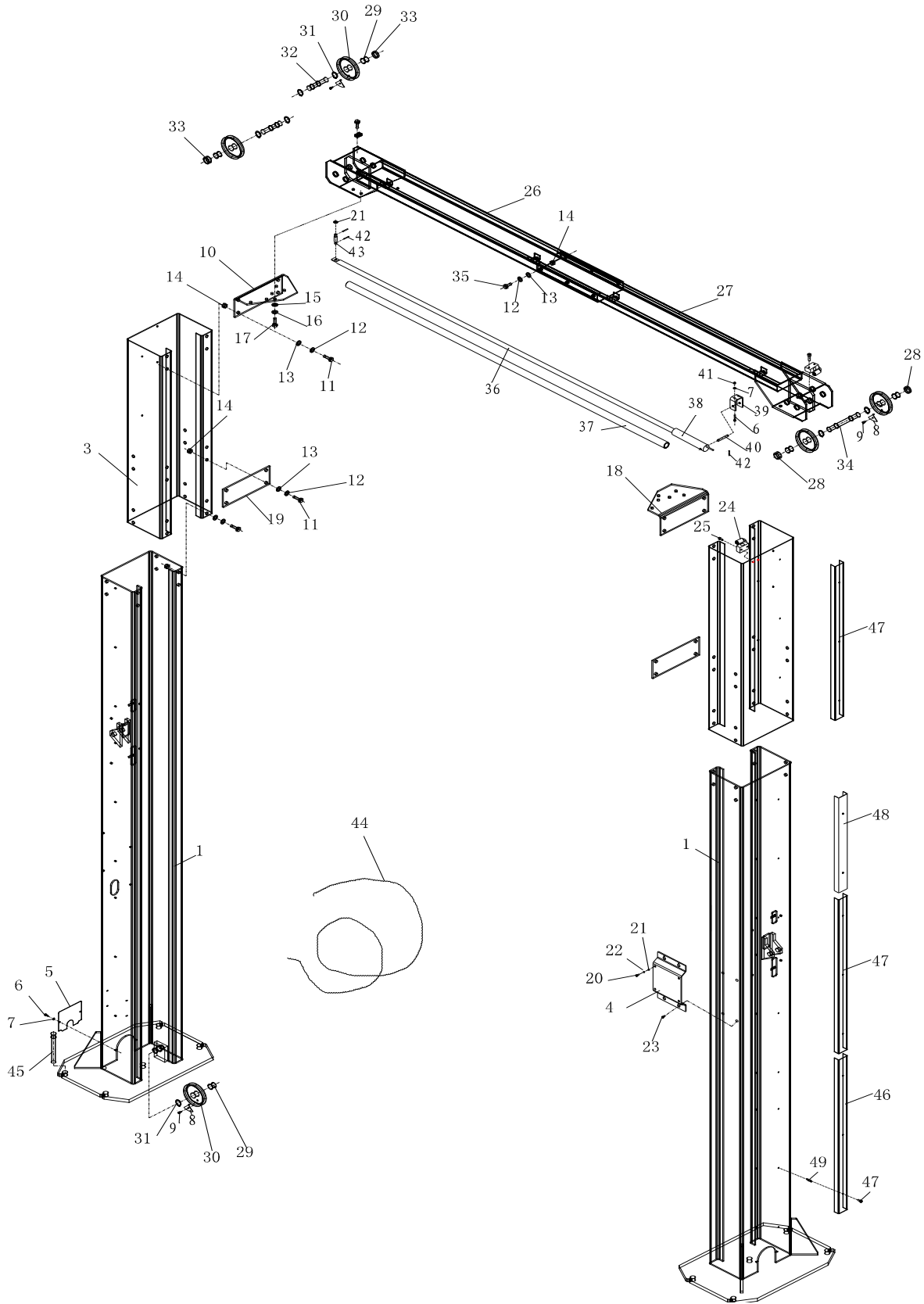

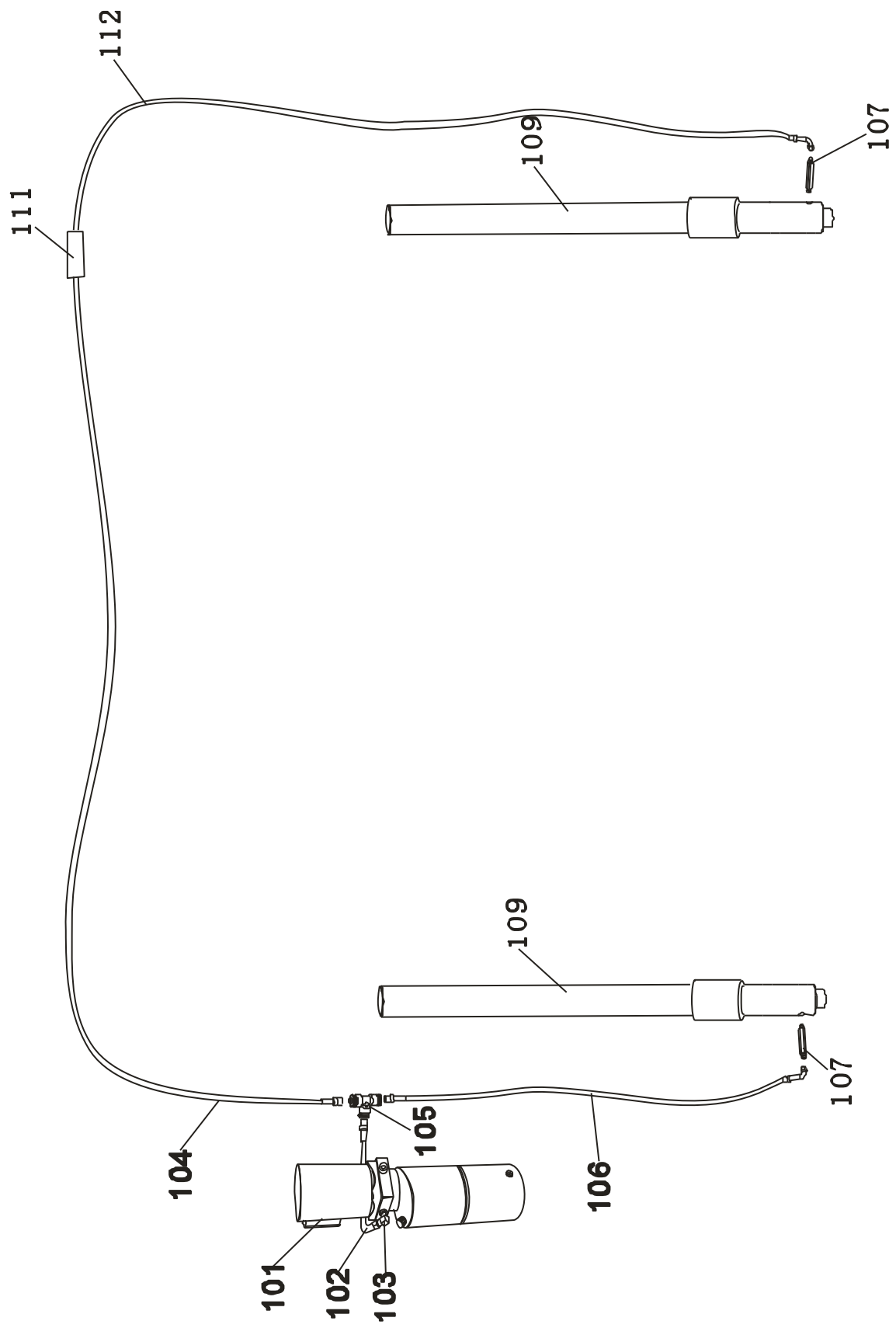

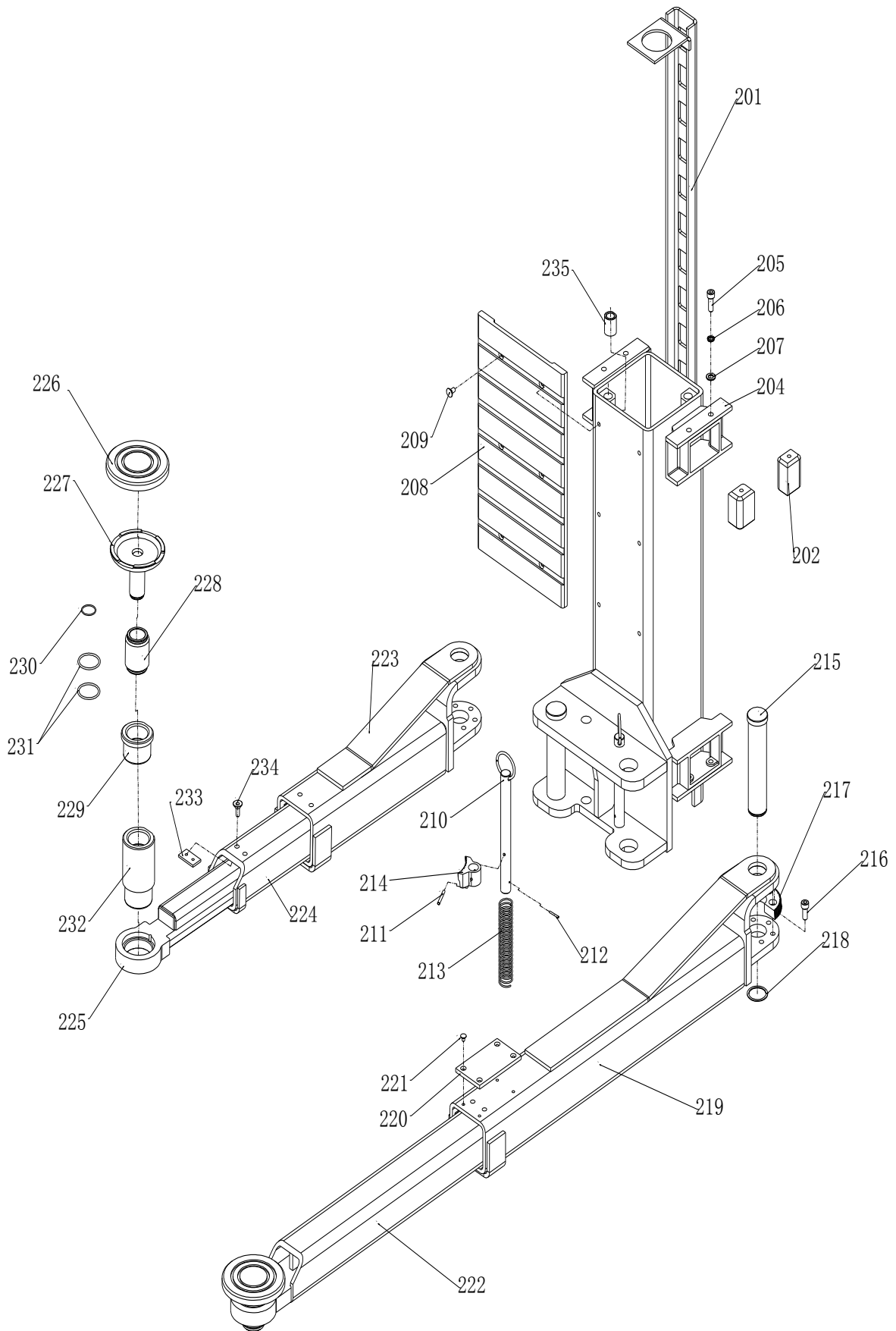

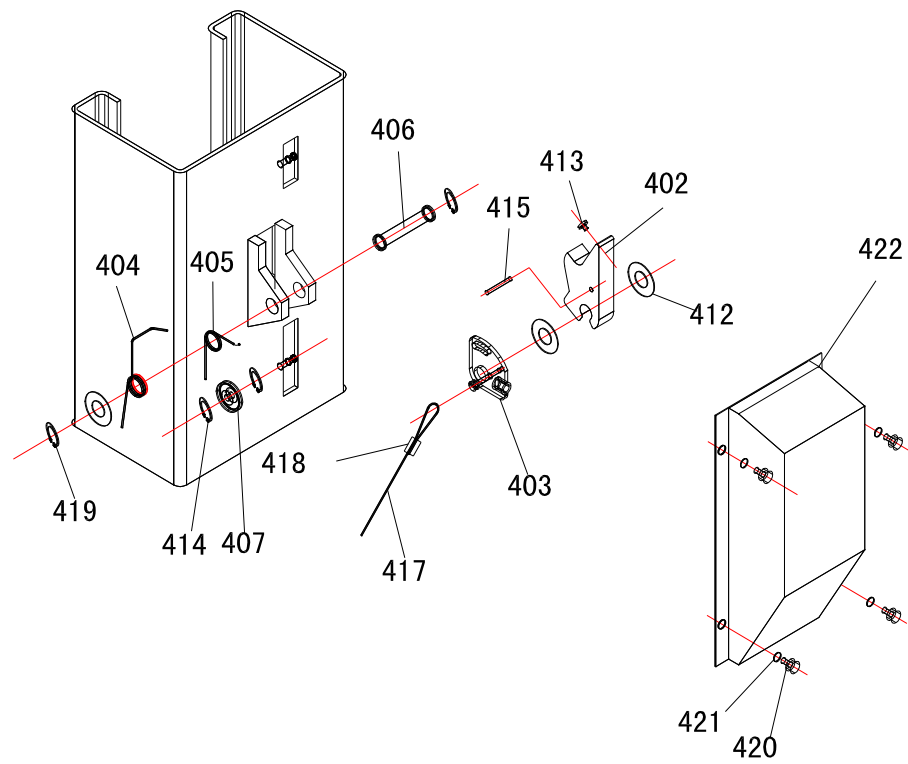
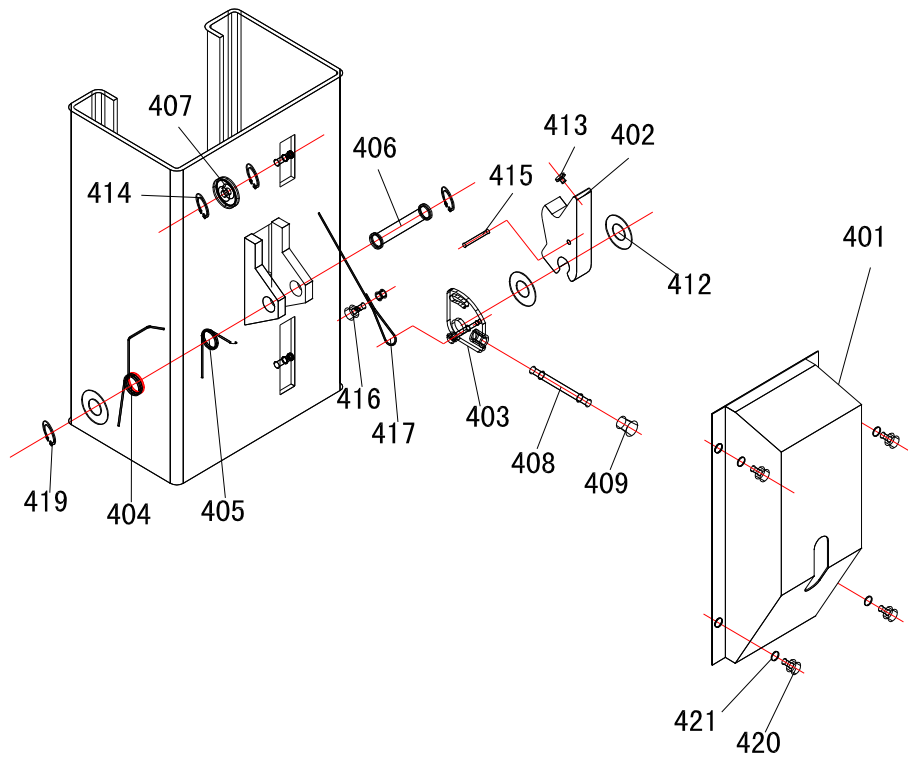

Location	Part Number	Description
1	201024604	Column
3	201014670	Column extension
4	201024608	Power unit bracket
5	103201070	Column bottom cover plate
6	103010432	screw M5*12
7	103040132	Flat washer
8	201013268	Lateral positioning palte
9	103020188	BoltM5×10
10	201011739	Connection bracket I
11	103020164	Bolt M12x35
12	103040044	Spring washer
13	103040110	Flat washer
14	103030129	Nut M12
15	103040123	Flat washer 10
16	103040122	Spring sealer, GB/T93-1987 11
17	103020207	Bolt M10x20
18	201011740	Connection bracket II
19	201011154	Reinforcement plate
20	103020100	Bolt M8X25
21	103040134	Flat washer 8
22	103040141	Spring washer, 8
23	103020171	Bolt M6×12
24	201024606	Cable guide block
25	103020163	Bolt M6X25
26	201021179	Outer overhead beam bracket
27	201020809	Inner overhead beam bracket
28	201011257	Sheave Spacer, Power Side, 8mm
29	103200699	Bush, SF-2 2520
30	201013282	Sheave
31	103050035	Elastic ring, 25,GB/T894.1-1987
32	103200966	Asymmetric shaft
33	201011258	Spacer I
34	103200967	Symmetric shaft
35	103020126	Bolt
36	201014671	Shutoff bar
37	104130196	Sleeve(inner hole Φ22),L=1.8M
38		Limit switch TS-10

39	201014672	Switch bracket
40	201014673	Switch shaft
41	103030018	Nut M5
42	103060342	Cotter pin 3*26,GB91-87
43	201011477	Shutoff shaft
44	103260260	Cable assembly
45	103020117	Anchor bolt M19*140
46	201014674	Column long hood at three-way fitting
47	201014675	Column long hood
48	201014676	Column short hood
49	201014685	Shaft for Hose hood
101		Power unit
102	104120132	Power unit hose
103	103202113	Adjustable right angle fitting
104	104120134	Overhead beam hose, L=5370
105	103100294	Three-way fitting
106	104120133	Hose, L=980
107	103100322	Flow control fitting assembly
109	103202112	Cylinder
111	103100295	Straight fitting
112	104120135	Idler column hose L=4250
201	201024611	Carriage
202	104990132	TLT235SB Slide block, strengthen nylon
204	201011855	Top board
205	103010473	Screw M10x30
206	103040122	Spring sealer, GB/T93-1987 11
207	103040123	Ring GB/T95-1985 11
208	104130191	TLT235SB Anti-shock pad,SBR,TLT235SB-20-03-A
209	103010539	Screw M8×12
210	103202184	Restraint shaft assembly
211	103060376	Pin 5*32
212	103060355	Cotter pin,3.2*30
213	103201914	Spring
214	103201744	Small gear block
215	201010982	Pin shaft
216	103010443	Bolt M10x25

217	103201771	Big gear block
218	103050030	Retaining ring 40
219	201021763	Long female arm
220	104130186	Arm rubber pad
221	103010608	Bolt M6x10
222	201021532	Long male arm
223	201024616	Front female arm
224	201024645	Front middle arm
225	201024646	Front male arm
226	104130315	Rubber pad
227	201021561	Threaded rod assembly
228	103202107	Dual-threaded adjustment sleeve
229	103202106	Support bracket
230	103050091	Retaining ring,30
231	103050090	Retaining ring,45
232	201014690	Long extension tube(optional)
	201014691	Short extension tube(optional)
233	201011475	Positioning plate
234	103010586	Bolt M8x12-12.9
235	201011741	Asymmetric adjustable bushing for asymmetric installation
	201011742	Adjustable bushing for narrow style installation
401	104090074	Lock release mechanism hood
402	201012086	Lock release plate
403	201020584	Cam (Power side)
404	103201450	Torsion spring I
405	103201451	Torsion spring II
406	103201455	Lock release plate shaft
407	202010074	Lock Release roller
408	103201454	Lock release latch
409	103260186	Latch cover BM10x50 (black)
412	201011156	Adjustment washer I
413	104130210	Small rubber pad
414	103050021	Retaining ring 9
415	103060333	Pin, 6*40
416	103260179	Cable Clamp 3
417	101060019	Cable,Φ1.4,L=8901

418	103201478	Cable clamp ϕ 2
419	103050025	Retaining ring 20
420	103010393	Screw,M8*12
421	103040134	Washer C,8
422	104090073	Idler lock release mechanism hood

Maintenance Records

Form #TLT210 1012011