

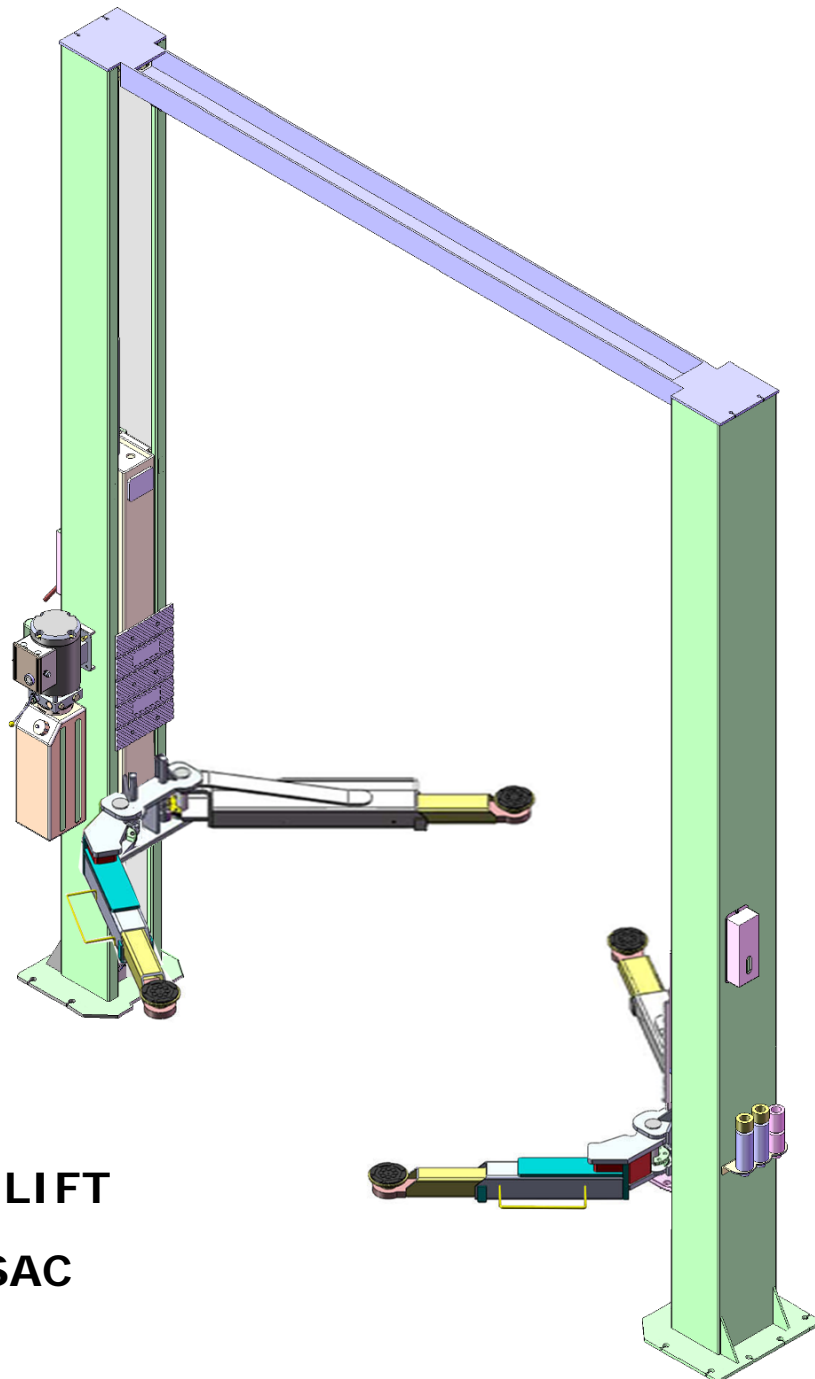

Installation And Service Manual



TWO-POST LIFT

Model:210SAC

CONTENTS

Product Features and Specifications	1
Installation Requirement	3
Steps of Installation	4
Exploded View	19
Test Run	23
Operation Instruction	25
Maintenance	25
Trouble Shooting	26
Parts List	27

I. PRODUCT FEATURES AND SPECIFICATIONS

CLEARFLOOR DIRECT-DRIVED MODEL FEATURES

MODEL 210SAC (See Fig.1)

- Direct-driving design, minimize the lift wear parts and breakdown ratio.
- Dual hydraulic direct-drive cylinders, designed and made on ANSI standard, utilizing oil seal in cylinder.
- Self-lubricating UHMW Polyethylene sliders and bronze bush.
- Single-point safety release, and dual safety design.
- Clear-floor design, provide unobstructed floor space.
- Overhead safety shut-off device.
- Super-asymmetric arms design can fit extremely wide vehicles.
- Stackable adapters 1.5", 2.5", 5" as standard.

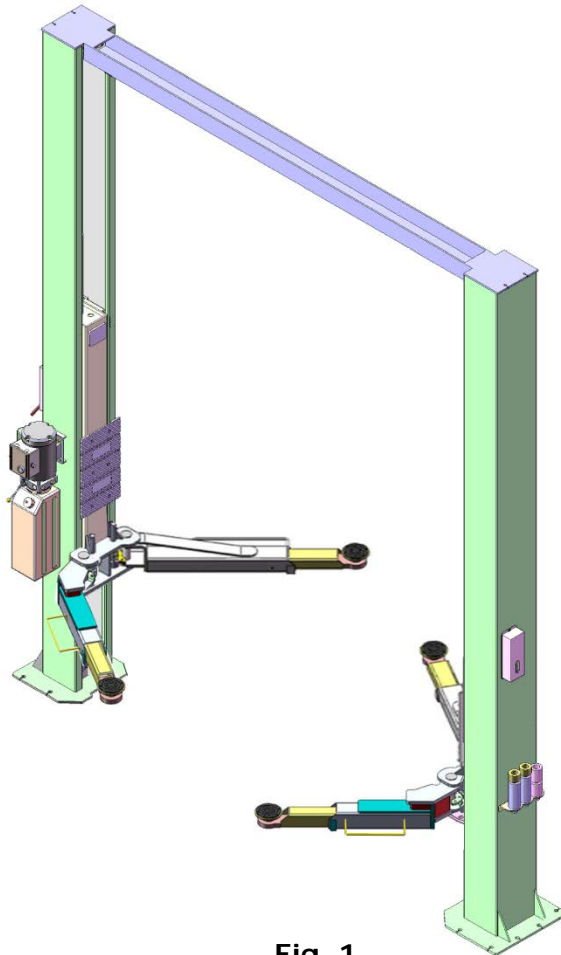
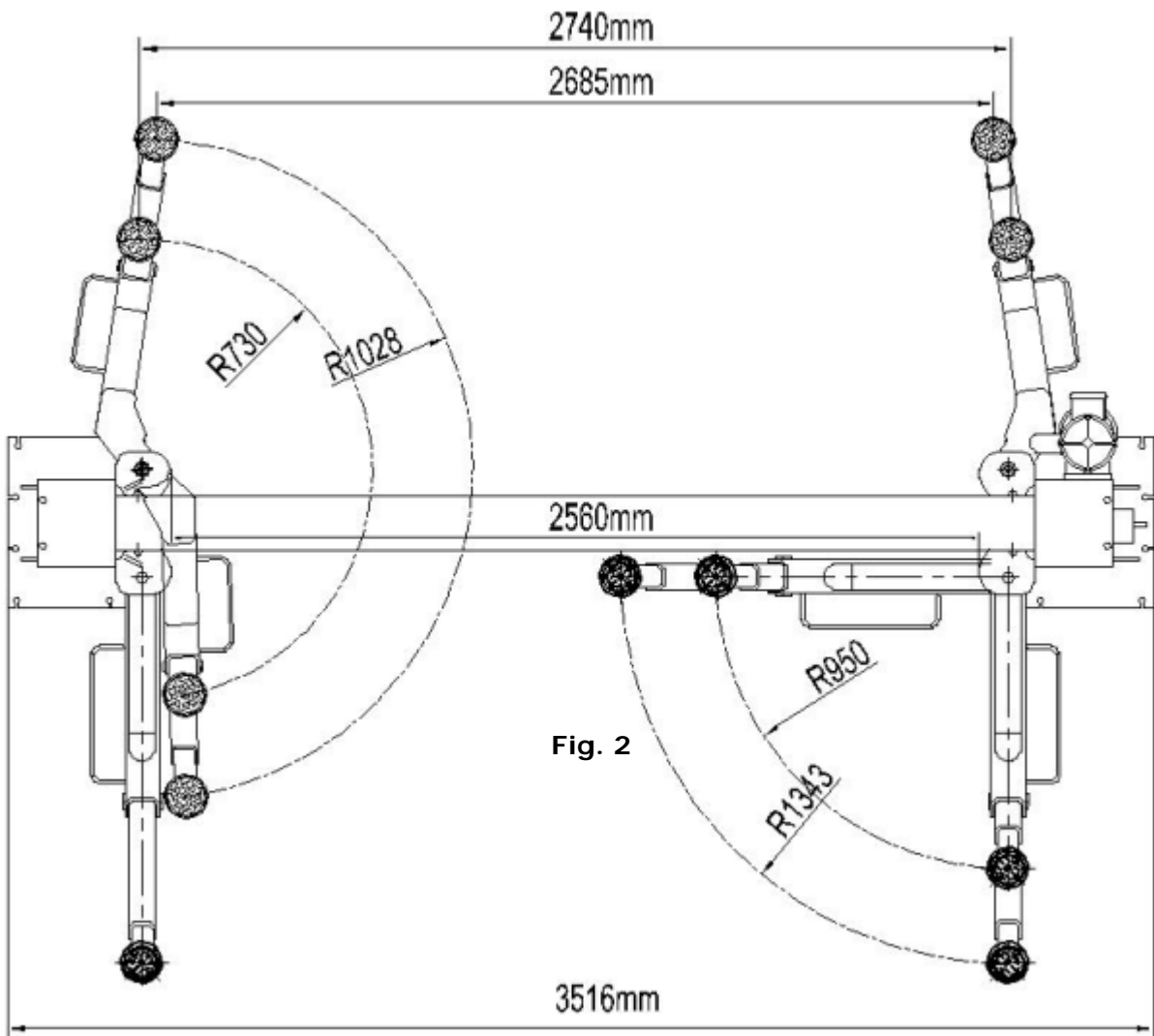

Fig. 1

MODEL 210SAC SPECIFICATIONS

Model	Style	Lifting Capacity	Lifting Time	Lifting Height	Overall Height	Overall Width	Width Between Columns	Minimum Pad Height	Gross Weight	Motor
210SAC	Clear-floor Direct-drive	4.5T 10,000lbs	60S	1940-2169mm 76 3/8"-85 3/8"	3854mm 151 3/4"	3516mm 138 3/8"	2850mm 112 1/4"	115mm 4 1/2"	762Kg 1,719lbs	3.0HP

210SAC Arm Swings View



II. INSTALLATION REQUIREMENT

A. TOOLS REQUIRED

- ✓ Rotary Hammer Drill ($\Phi 19$)



- ✓ Hammer



- ✓ Level Bar



- ✓ English Spanner (12")



- ✓ Ratchet Spanner With Socket (28#)



- ✓ Wrench set
(10#, 13#, 14#, 15#, 17#, 19#, 24#, 27#)



- ✓ Carpenter's Chalk



- ✓ Screw Sets



- ✓ Tape Measure (7.5m)



- ✓ Pliers



- ✓ Socket Head Wrench (3#, 6#)



- ✓ Lock Wrench



B. SPECIFICATIONS OF CONCRETE (See Fig. 4)

Specifications of concrete must be adhered to the specification as following.
Failure to do so may result in lift and/or vehicle falling.

1. Concrete must be thickness 100mm minimum and without reinforcing steel bars, and must be dried completely before the installation.
2. Concrete must be in good condition and must be of test strength 3,000psi (210kg/cm²) minimum.
3. Floors must be level without cracks.

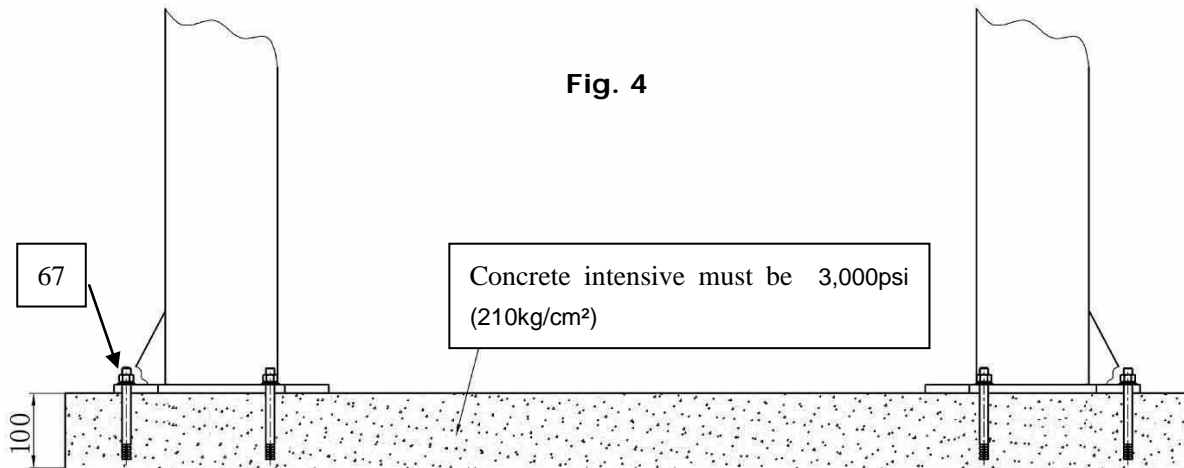

Fig. 4

C. POWER SUPPLY

The electrical source must be 3.0HP minimum. The source cable size must be 2.5mm² and in good condition of contacting with floor.

III. STEPS OF INSTALLATION

A. Location of Installation

Check and insure the installation location (concrete, layout, space size etc.) is suitable for lift installation.

B. Use a carpenter's chalk line to establish installation layout of baseplate (See Fig. 5).

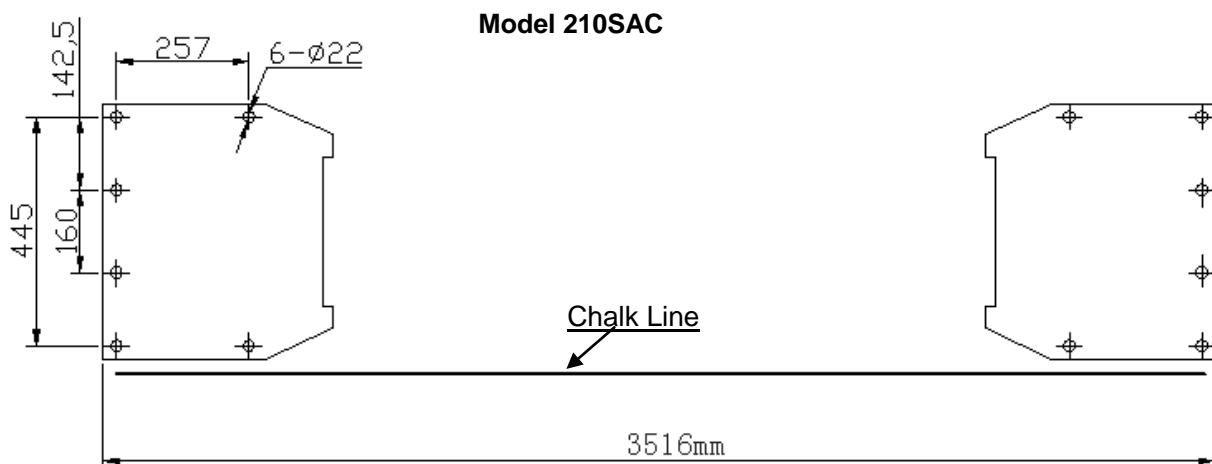

Model 210SAC

Fig. 5

C. Check the parts before assembly

1. Packaged lift and hydraulic power unit (see Fig. 6)



Fig. 6

2. Move the lift aside with a fork lift or hoist, and open the outer packing carefully , take off the parts from upper and inside the column, take out the parts box, check the parts according to the shipment parts list (See Fig. 7).

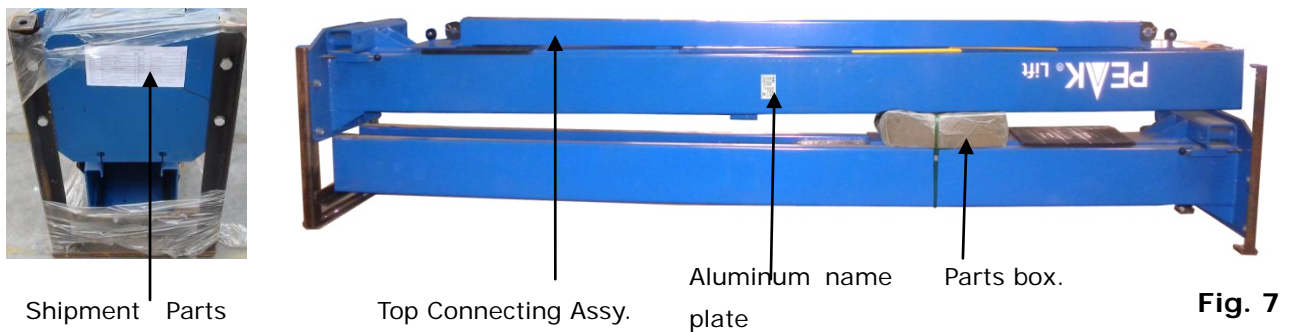

Fig. 7

3. Loose the screws of the upper package stand, take off the upper column and remove the package stand.
4. Move aside the parts and check the parts according to the shipment parts list (See Fig. 8,9).



Fig. 8

Parts in the shipment parts list

76



Fig. 9

Parts in the parts box (76)

5. Open the bag of parts and check the parts of the parts bag according to parts bag list (See Fig. 10).

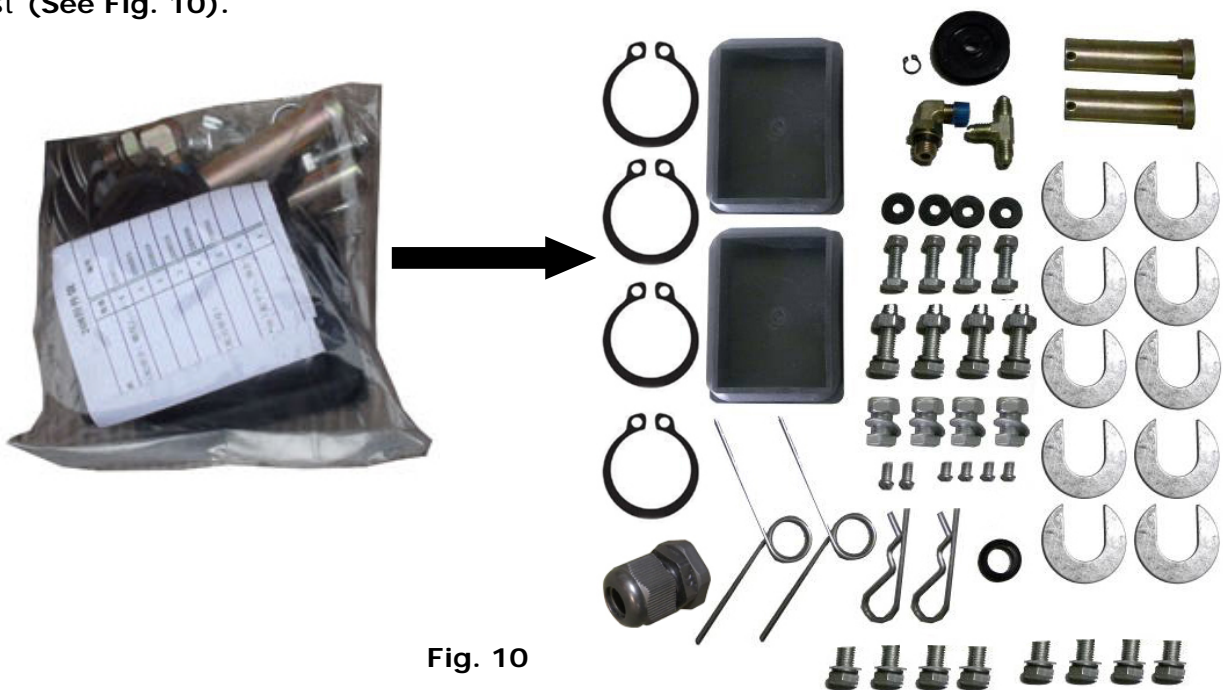

Fig. 10

D. Position powerside column

Lay down two columns on the installation site parallelly, position the powerside column according to the actual installation site. Usually, it is suggested to install powerside column on the front-right side from which vehicles are driven to the lift (See Fig. 11).

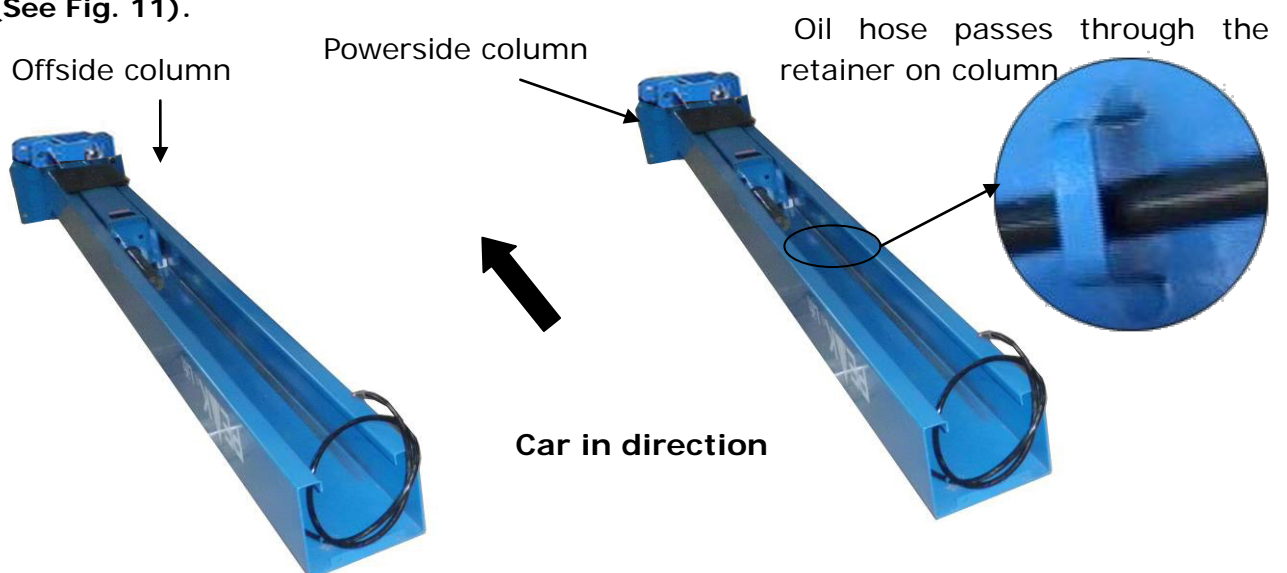

Fig. 11

E. Connecting oil hose

Push the carriages, connecting the cylinder fittings and then connect the oil hose to the cylinder. (See fig.12)



Install cylinder fittings and oil hose



Mounted

Fig. 12

F. Connecting cables

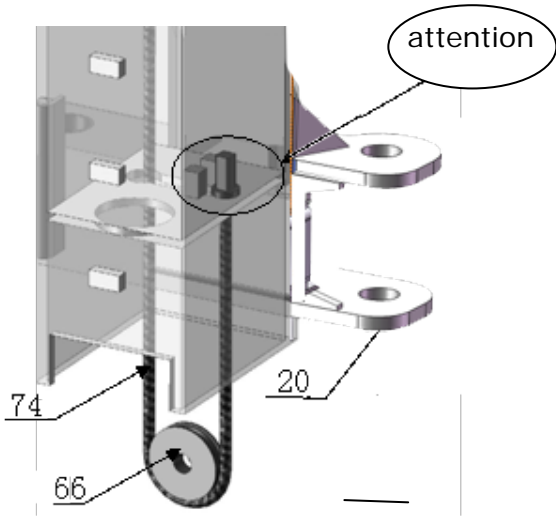

Cable pass through from the bottom of the carriages

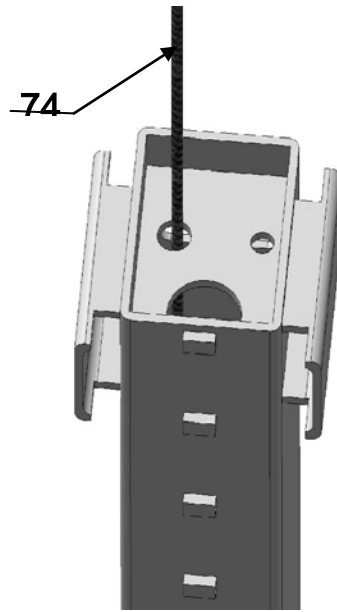

Cable pass through the top plate of the carriages

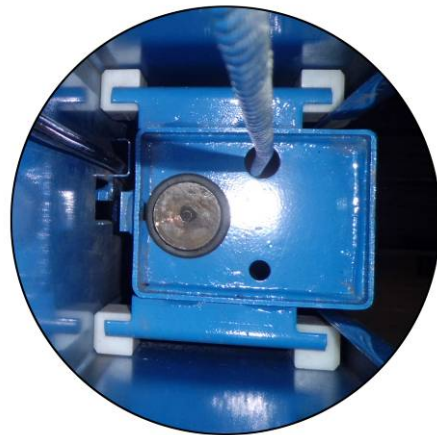
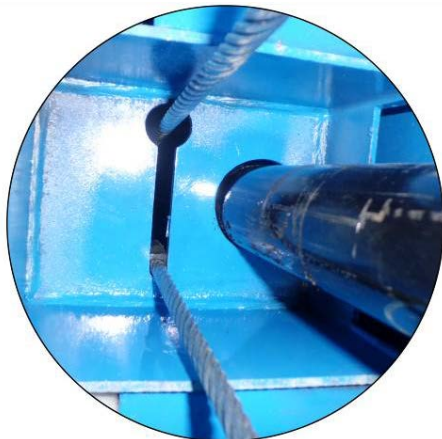

Fig. 13

G. Lay down aside the columns with cables and oil hoses installed, face the open way of each columns.

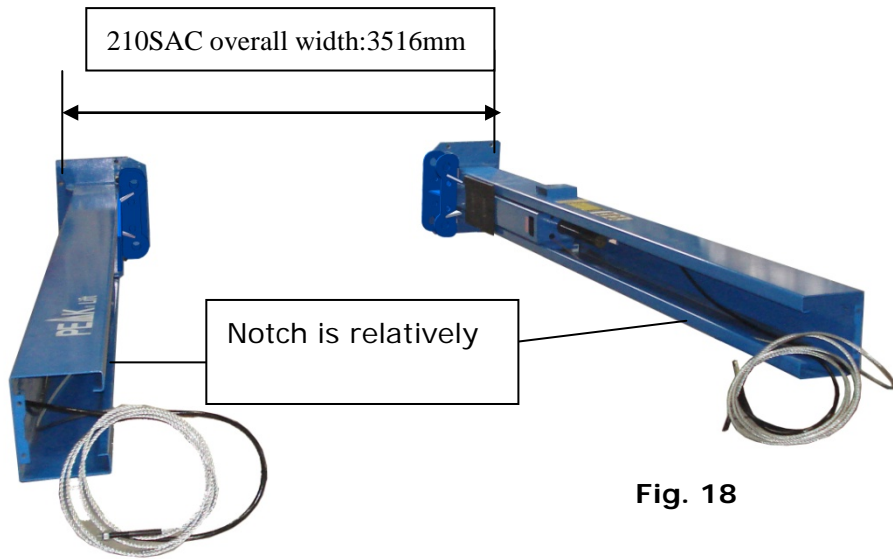

Fig. 18

H. Position columns

Position the columns on the installation layout of baseplate. Install the anchor bolts. Do not tighten the anchor bolts (See Fig.15).

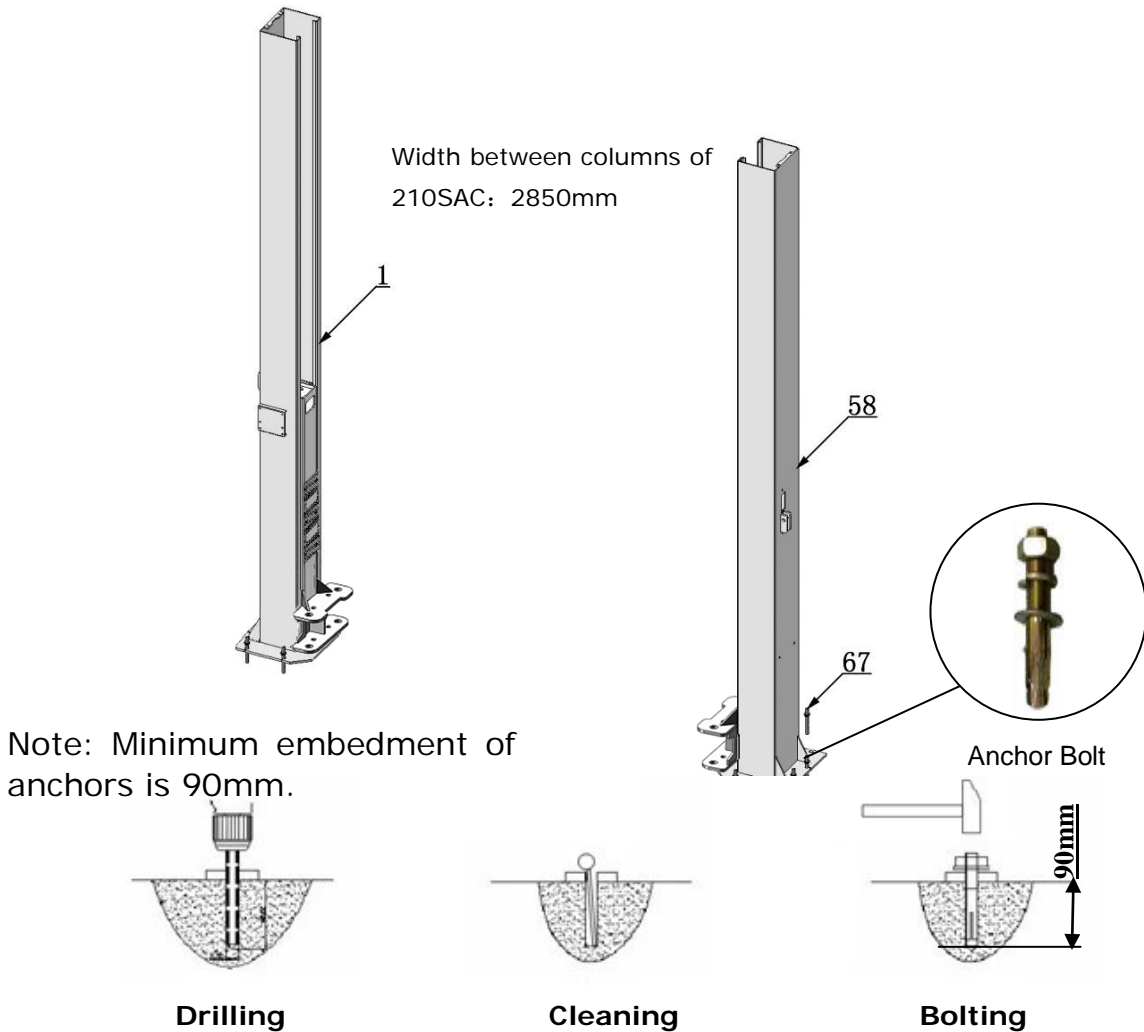

Fig. 15

I. Assemble overhead top beams (See Fig.16).



Fig. 16

J. Check the columns plumbness with level bar, and adjusting with the shims if the columns are not vertical. Tighten the anchor bolts (See Fig.17).

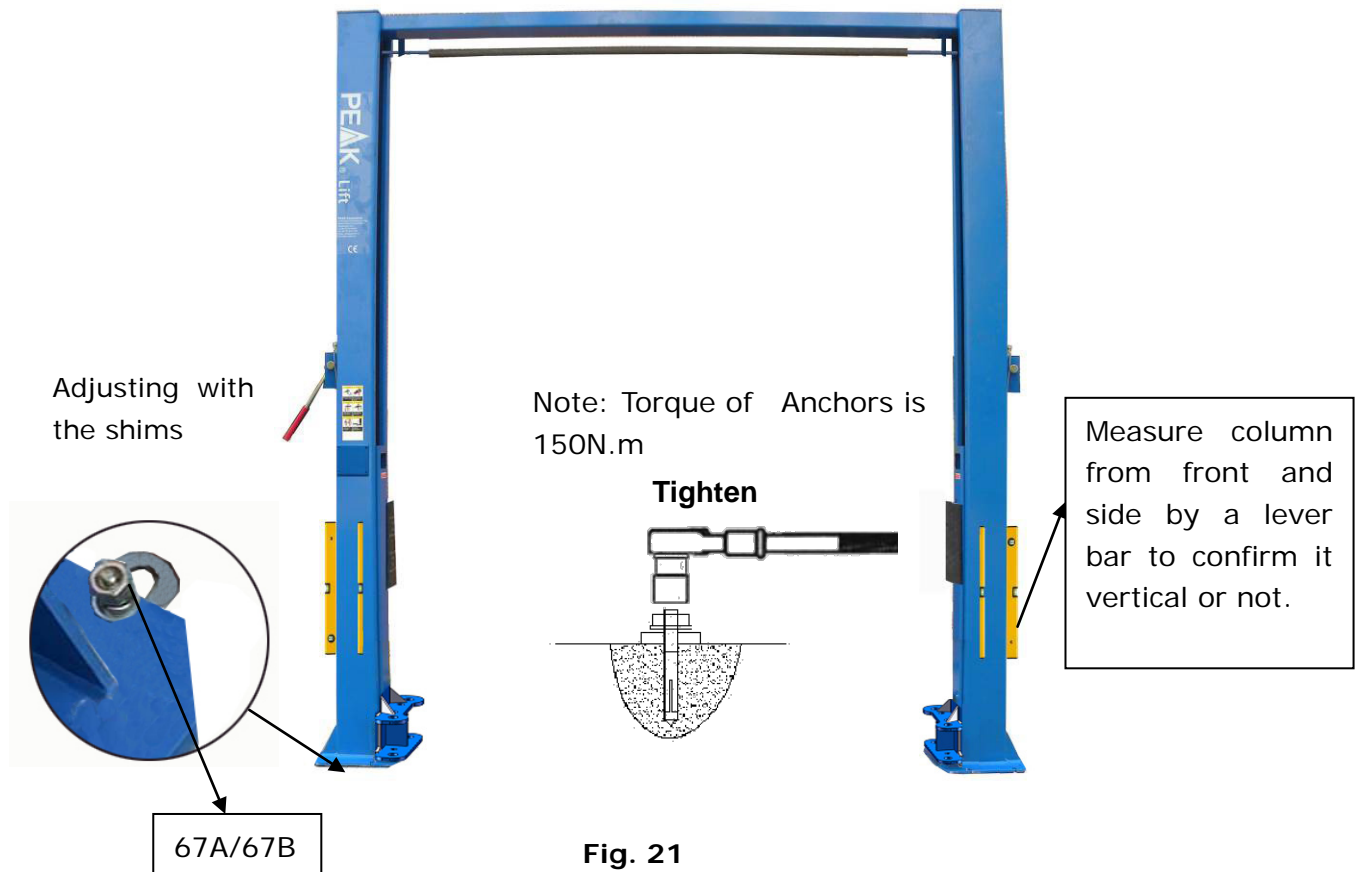

Fig. 21

K. Install the limit switch control bar and limit switch (See Fig. 18).

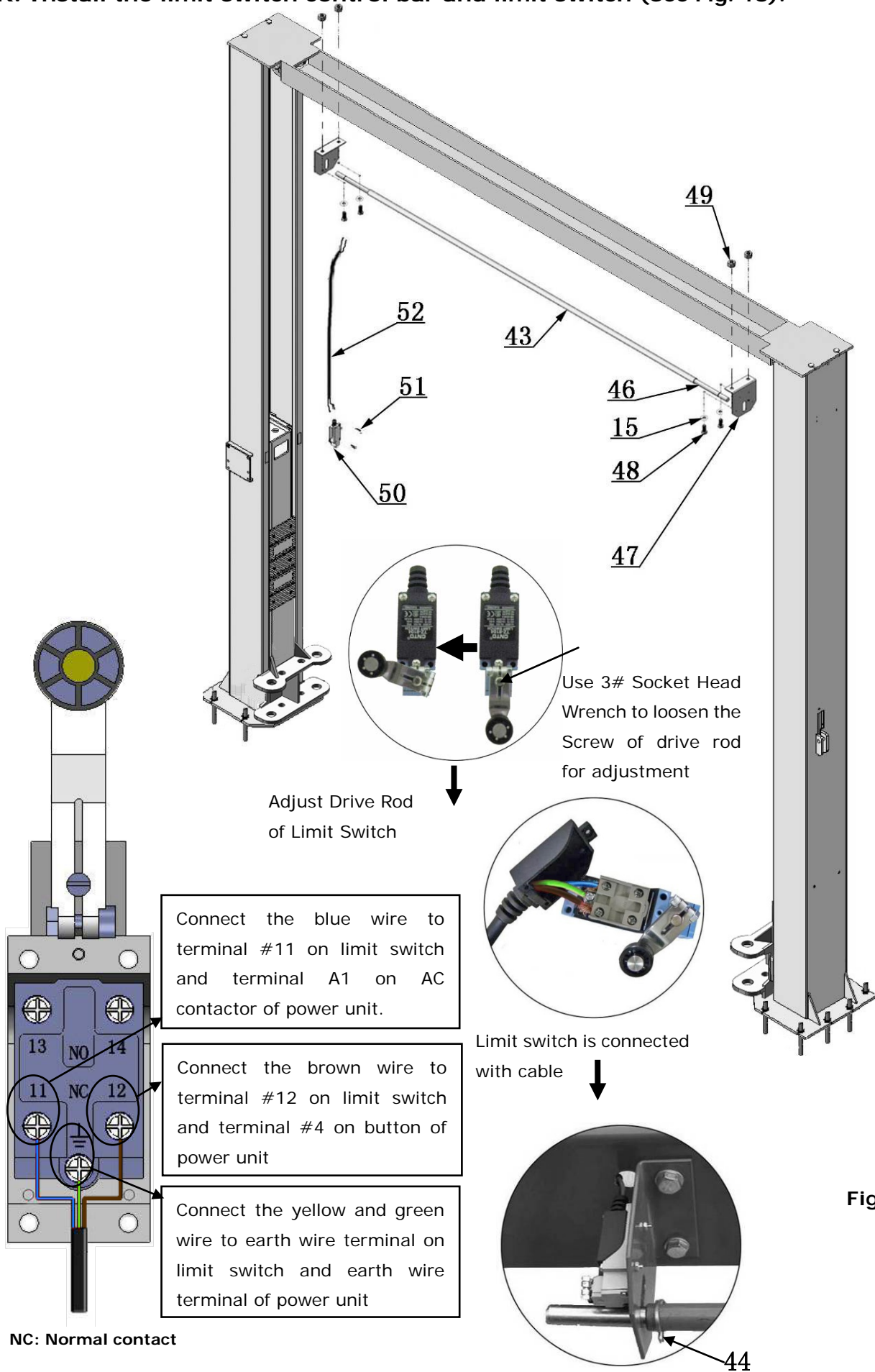

Fig. 18

L. Install safety cable (See Fig. 19).

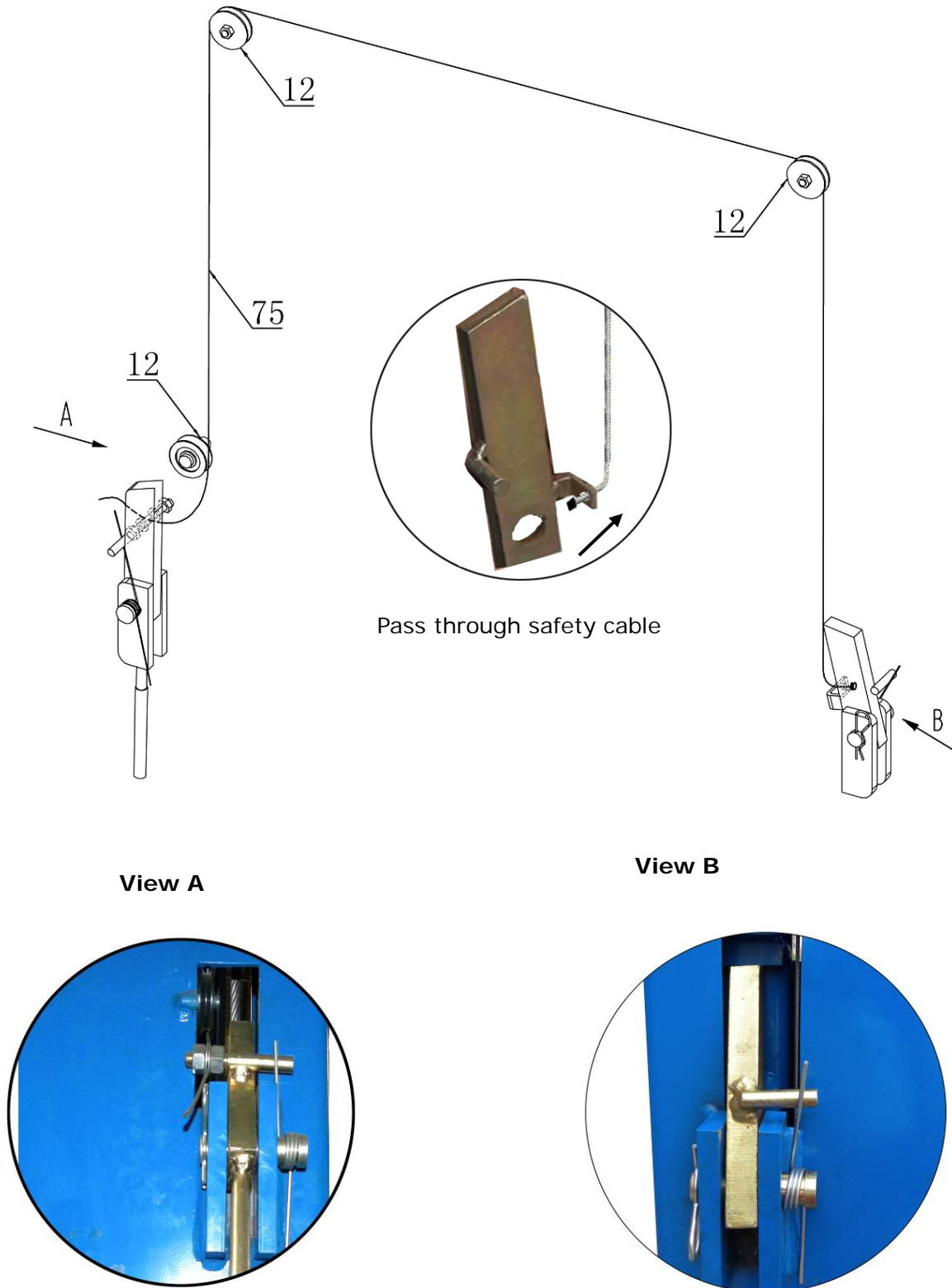

Fig. 23

M. Install cables (See Fig. 20).

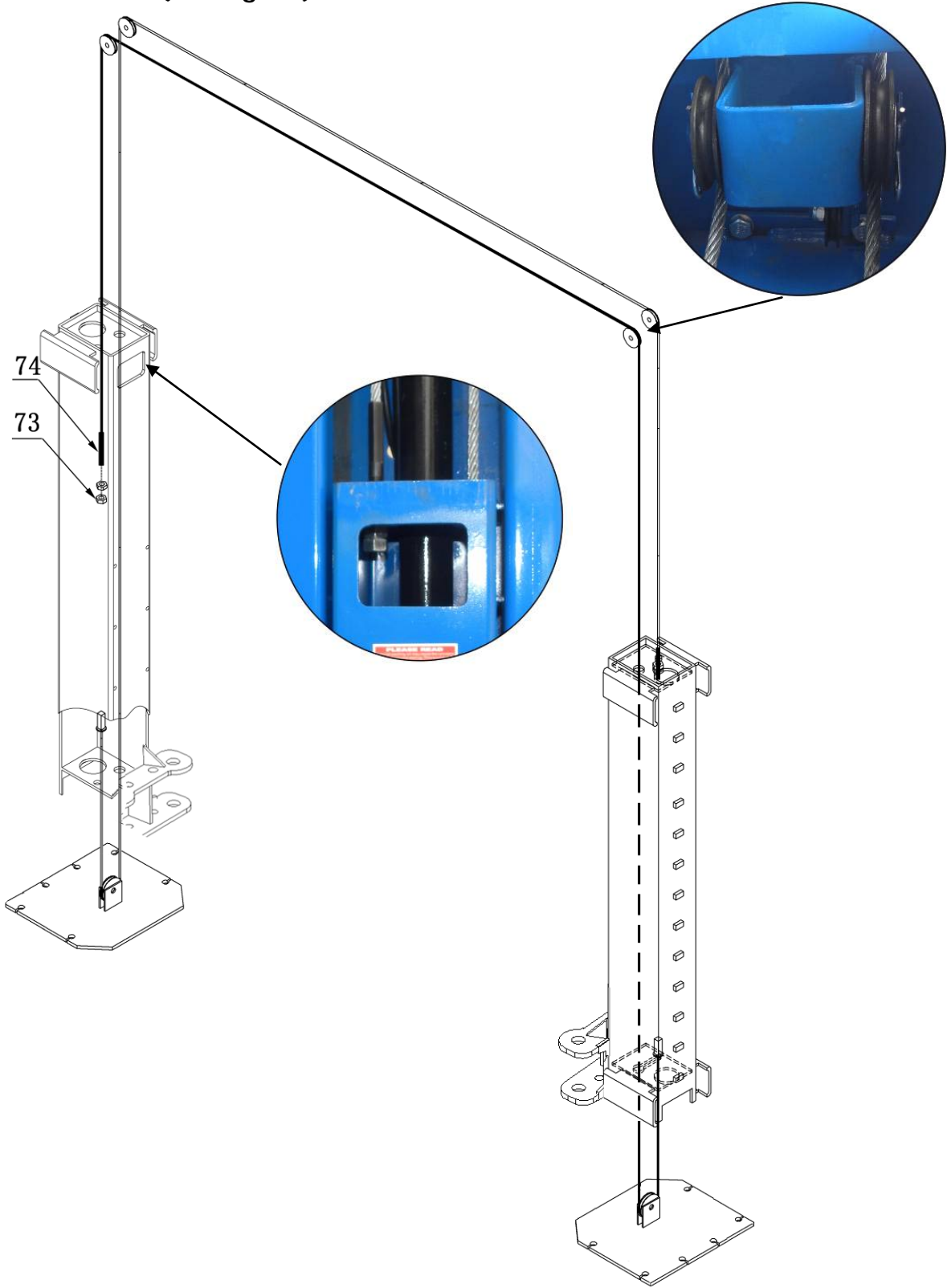

Fig. 24

N. Assembly oil hose assy (See Fig. 2)

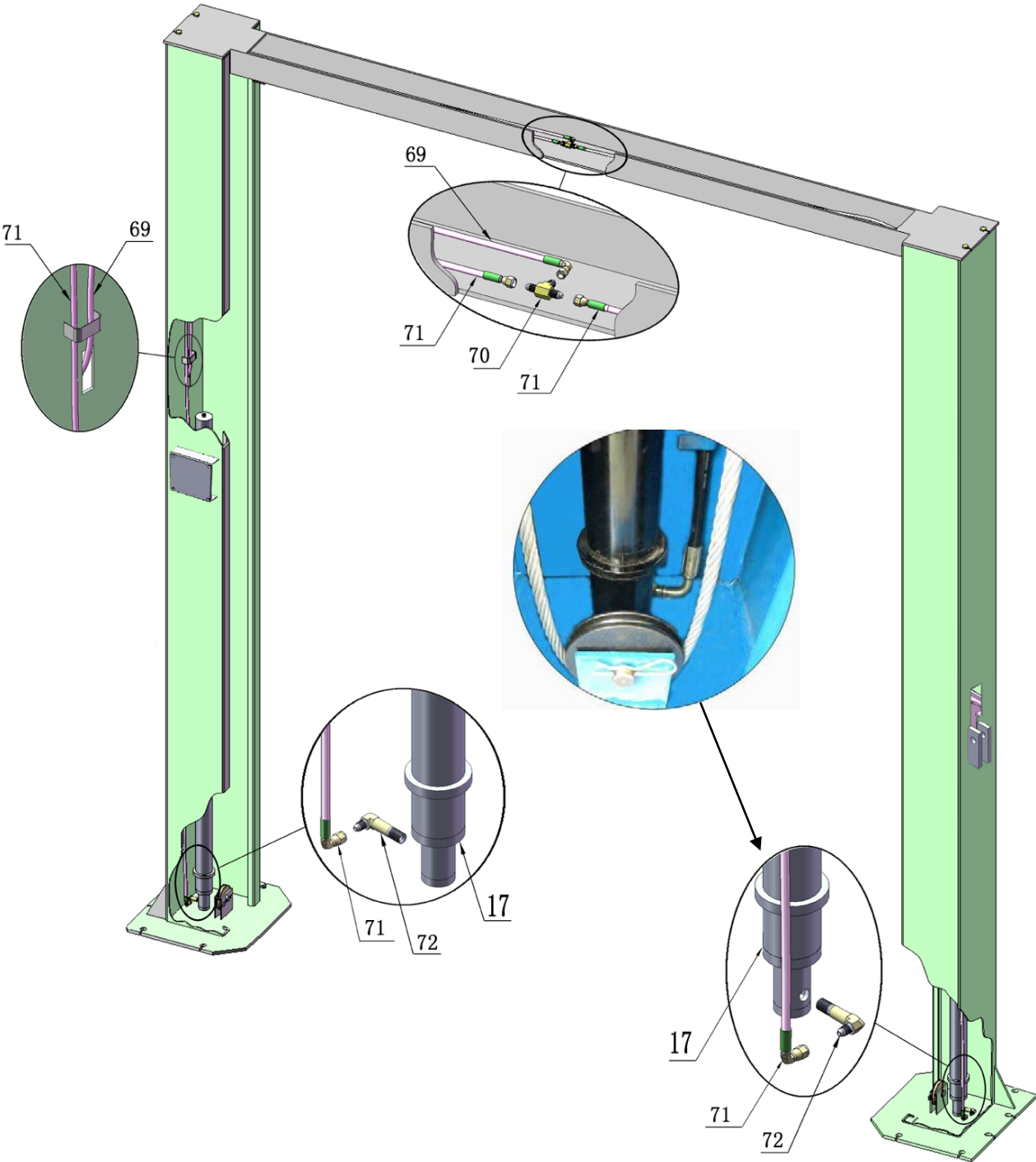

Fig. 21

O. Install power unit and oil hoses (See Fig. 22)

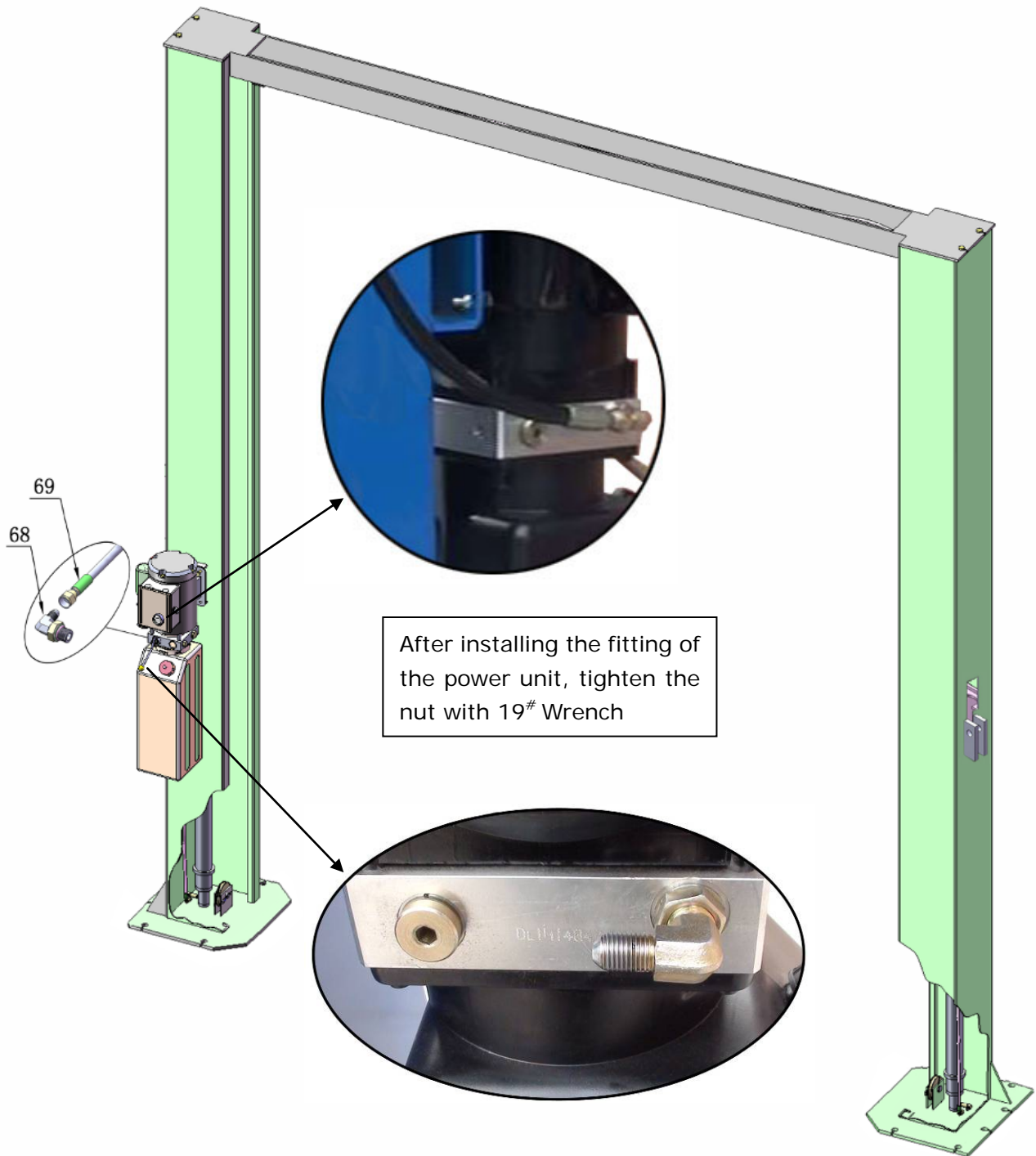

Fig. 22

P. Install lifting arms and adjust the arm locks

1. Install the lifting arms (See Fig. 23).
2. Lowering the carriages down to the lowest position, then use the 8# wrench to loosen the nut of arm lock (See Fig. 24).

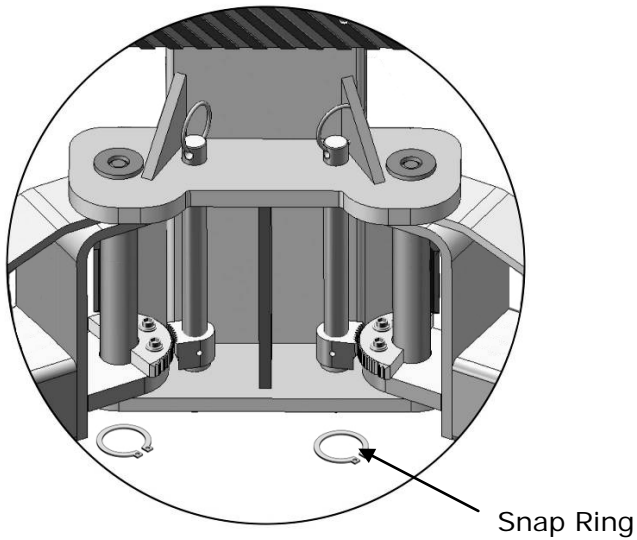

Fig. 23

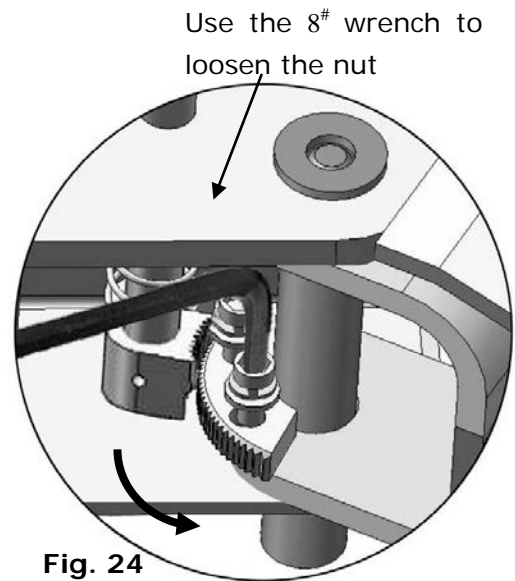

Fig. 24

3. Adjust the arm lock as direction of arrow (See Fig. 25)

4. Adjust the moon gear and arm lock to make it to be meshed, then tighten the nut of arm lock (See Fig. 26).

Adjust the moon gear

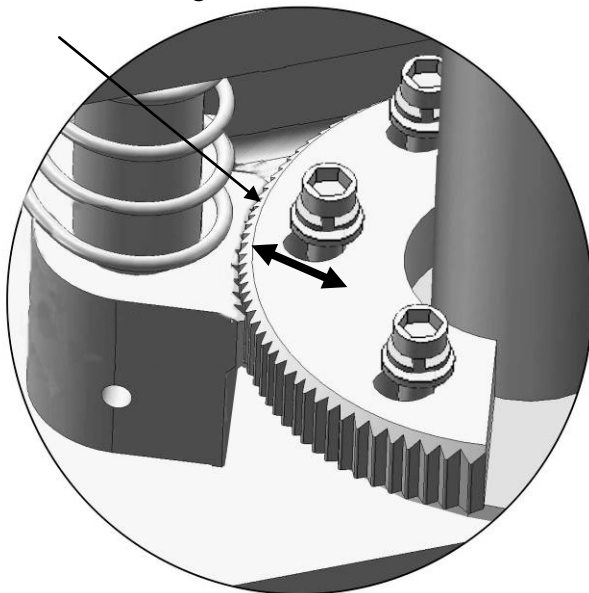

Fig. 25

Locking the nuts after the moon gear and arm lock engaged well

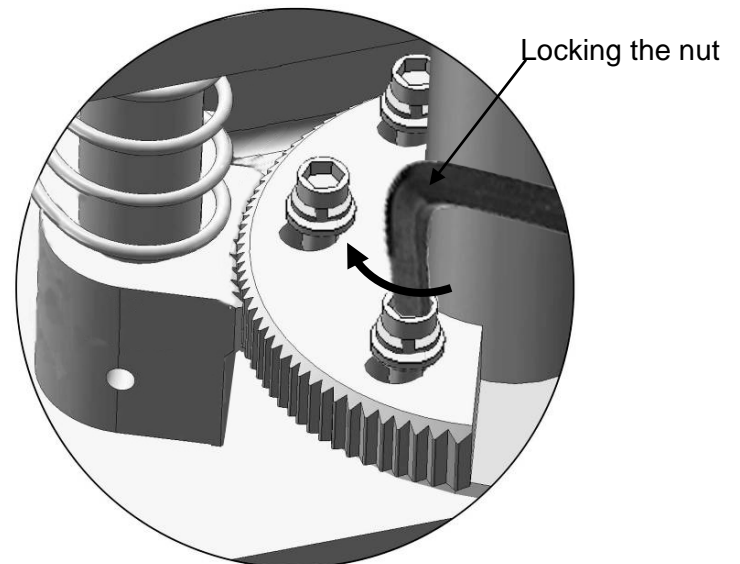

Fig. 26

Q. Tighten all the hydraulic fittings, and fill the reservoir with hydraulic oil.

Note: In consideration of Hydraulic Power Unit's durability and keep the equipment running in the perfect condition, please use Hydraulic Oil 46#.

R. Install electrical system

Connect the power source on the data plate of power unit.

- Note:** 1. For the safety of operators, the power wiring must contact the floor well.
2. Pay attention to the direction of rotations when using three phase motors.

PEAK single phase motor (See Fig. 27).

1. Connecting the two power supply lines (Active **L** and Neutral wire **N**) to terminals of AC contactor marked **L1**, **L2** respectively.
2. Connecting the two motor wires to terminals of AC contactor marked **T1**, **T2**.
3. Connecting **A2** to **L2** of AC contactor.
4. Connecting the Limit Switch: Removing the wire of connecting terminal **4#** on control button and terminal **A1** on AC contactor firstly (See Fig. 28), then connecting wire **12#** (brown color) of the limit switch with terminal **4#** of the control button and connecting wire **11#** (blue color) with terminal **A1** on AC contactor respectively. Connecting the earth wire (green and yellow color) of the limit switch with earth wire terminal on power unit. (See Fig. 29).
5. Connecting terminal **3#** on control button with terminal **L1** of AC contactor.

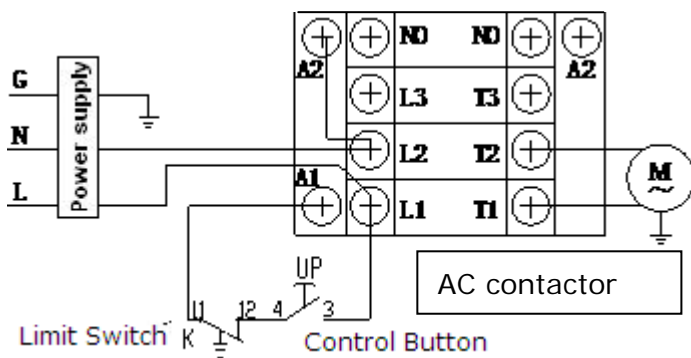

PEAK POWER UNIT

Fig. 32

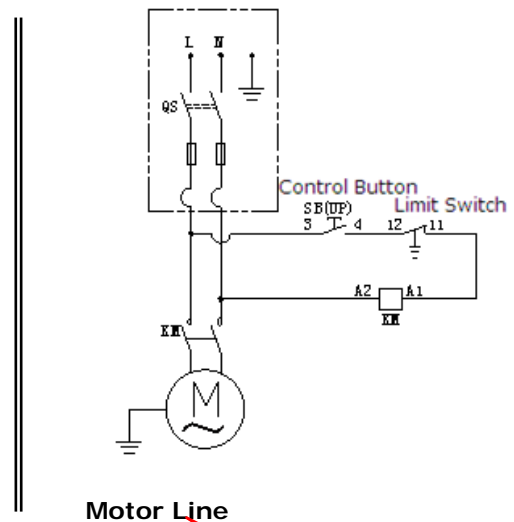

Motor Line

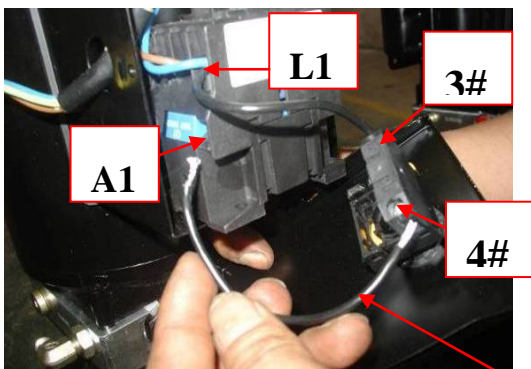

Fig. 28

Remove this wire before connecting the Limit Switch

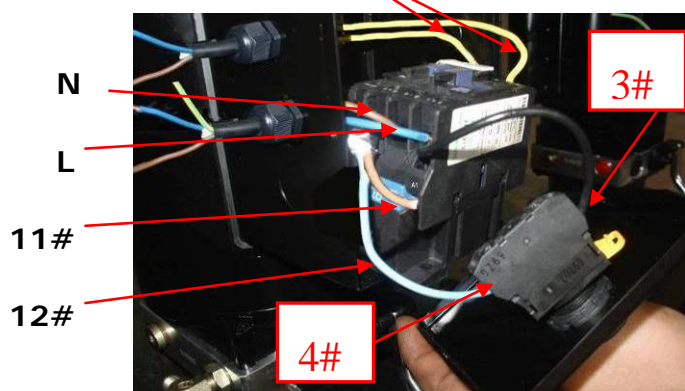

Fig. 29

SPX single phase motor (See Fig. 30)

1. Power supply line (Neutral wire **N**) connected with wire **5#** of motor.
2. Wire **11# (blue wire)** of limit switch is connected with wire **6#** of motor.
3. Wire **12# (brown wire)** of limit switch is connected with wire **4#** of control button.
4. Earth wire(yellow and green wire) of limit switch is connected with terminal earth wire of power unit.
5. Wire 3# on control button is connected with active wire(L) of the power supply.

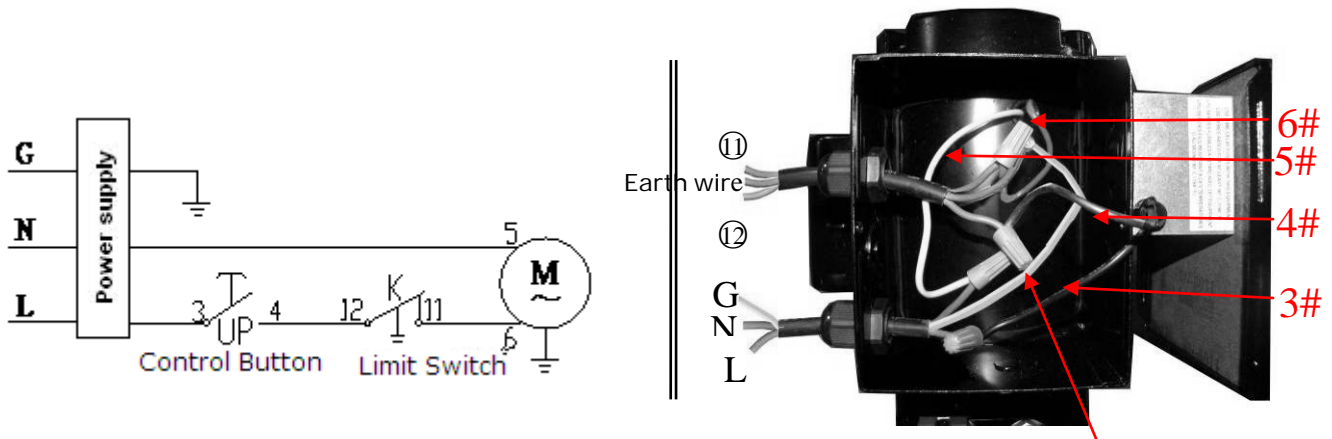

Fig. 30

Earth wire

Three phase motor

1. Circuit diagram (See Fig. 31)

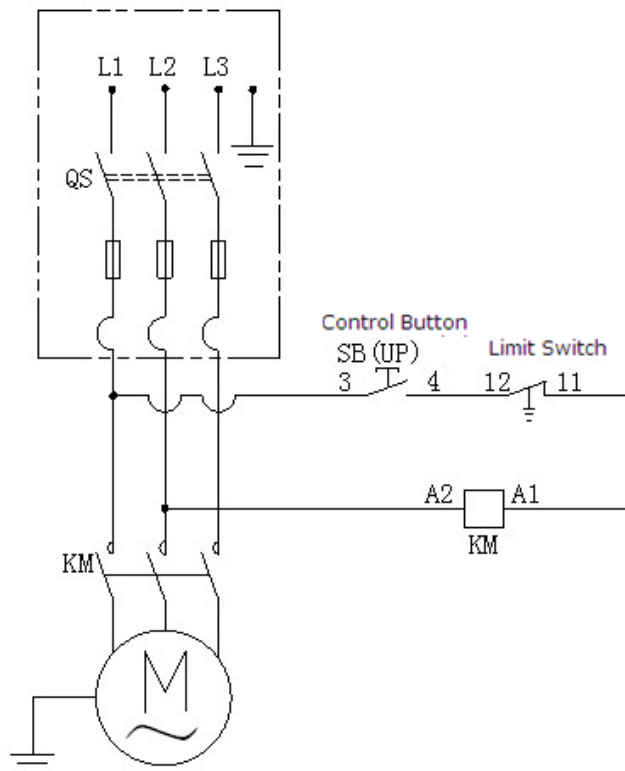

Fig. 31

2. Connection step (See Fig. 32)

- a. The source wires (**L1, L2, L3**) connected with terminals of AC contactor marked **L1, L2, L3** respectively.
- b. Terminals **4#** of control button connected with wire **12#** (brown wire) of limit switch; wire **11#** (blue wire) connected with **A1** terminals of AC contactor, Earth wire (yellow and green wire) of limit switch is connected with terminal earth wire of the motor.
- c. Terminals **3#** of control button connected with **L1** terminals of AC contactor.

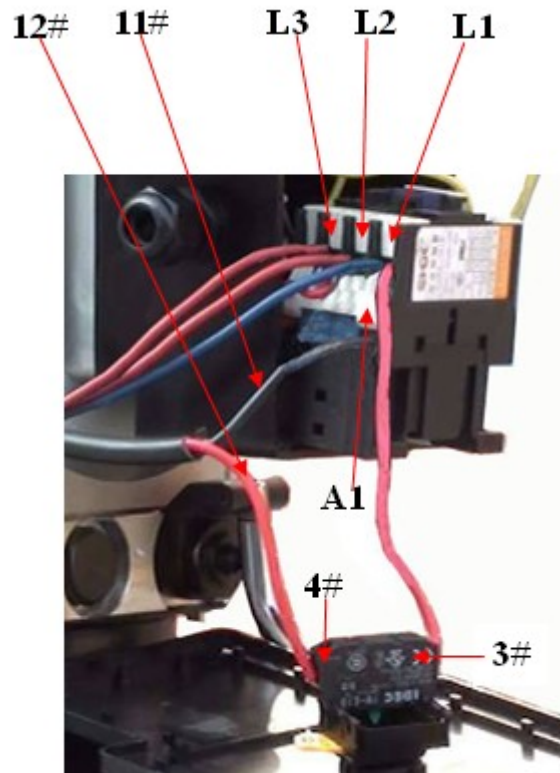
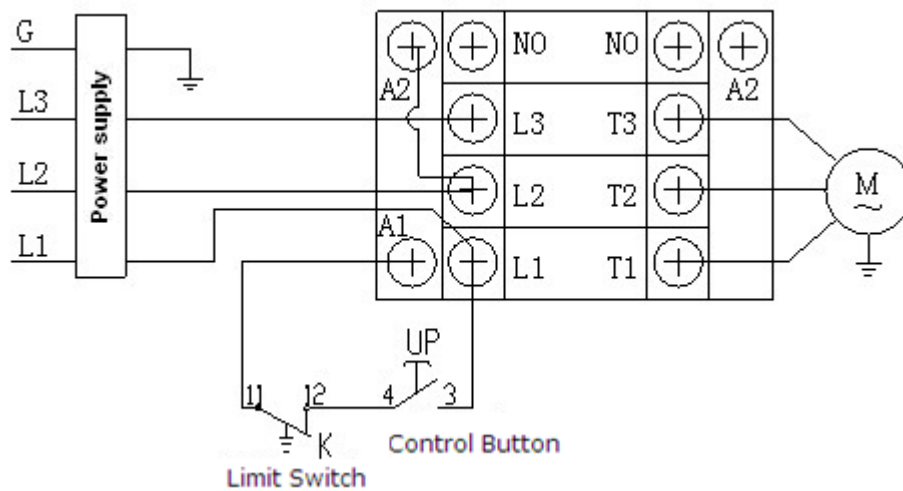

Fig. 32

IV. EXPLODED VIEW

Model 210SAC

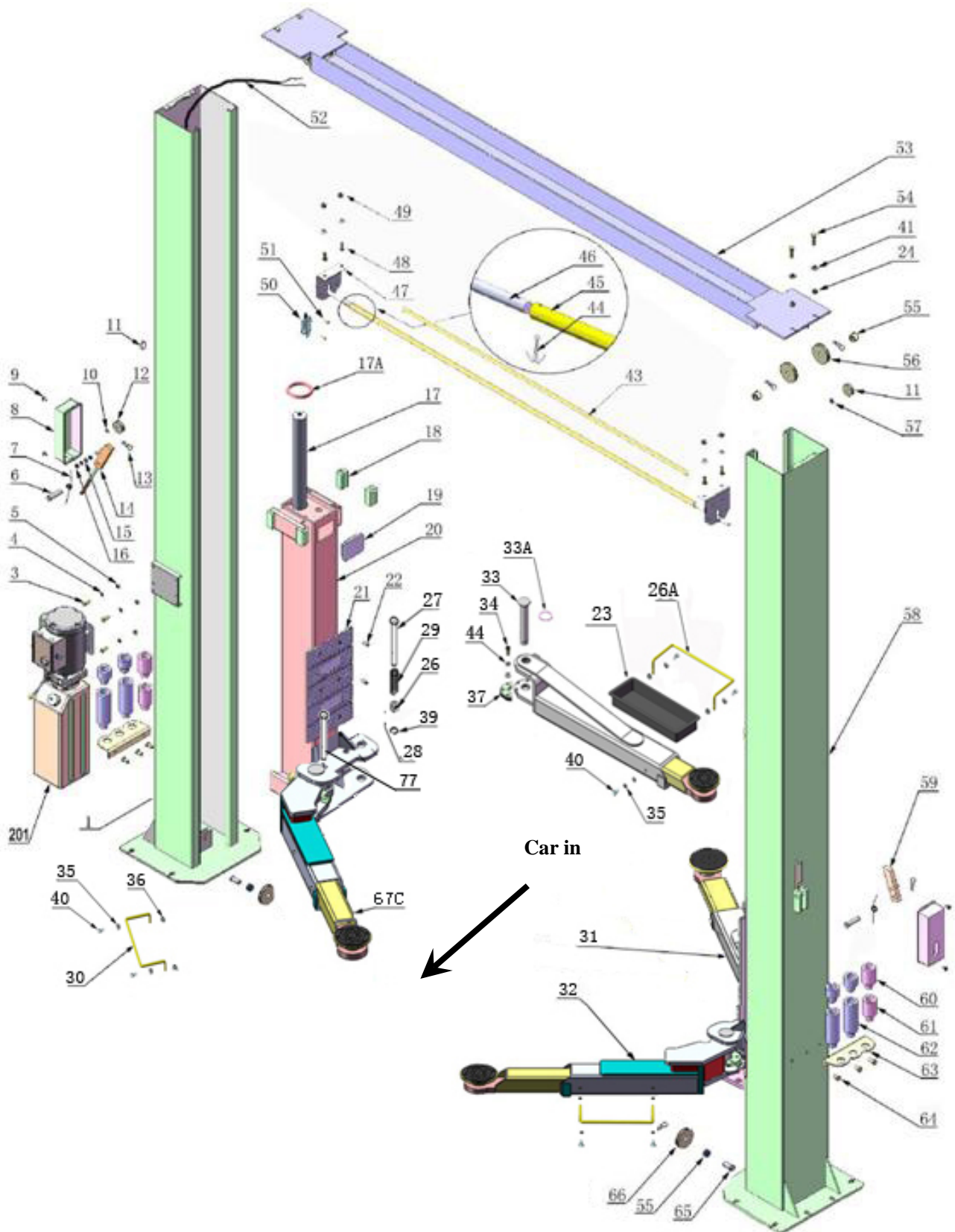
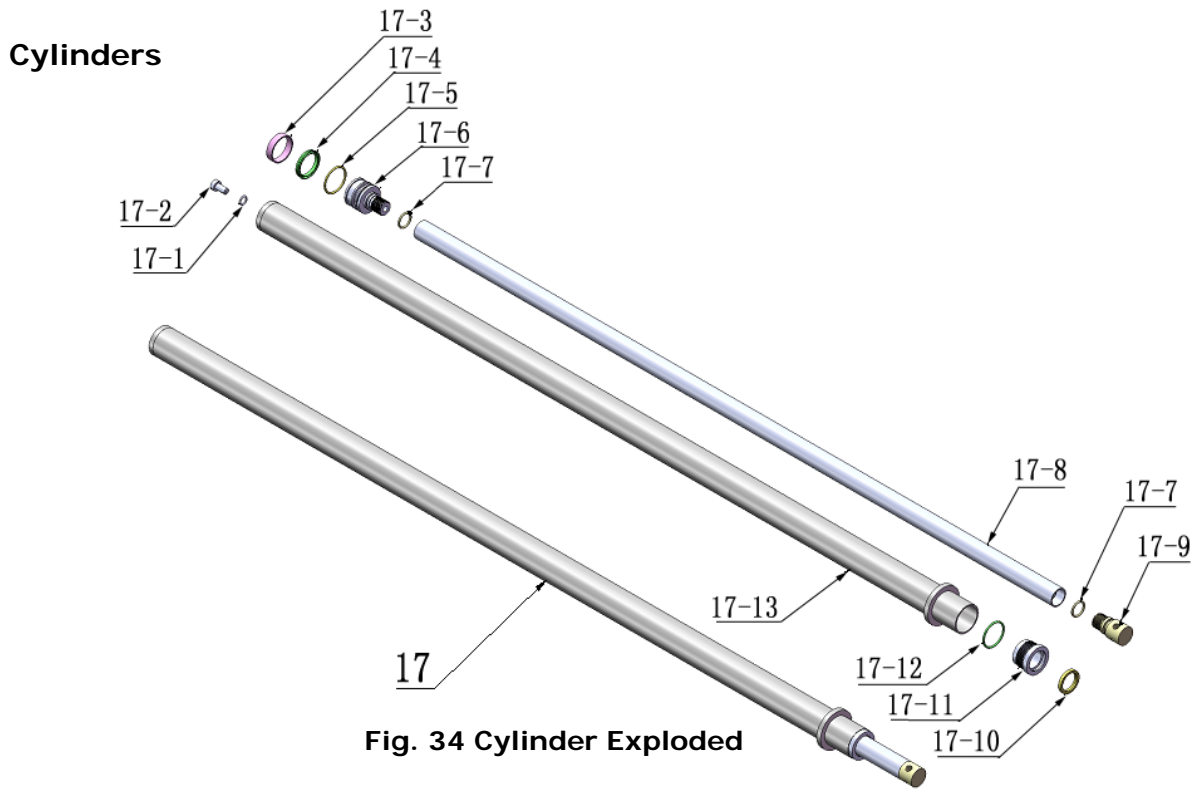

Fig. 33



SPX MANUAL POWER UNIT, 220V/50Hz, Single phase

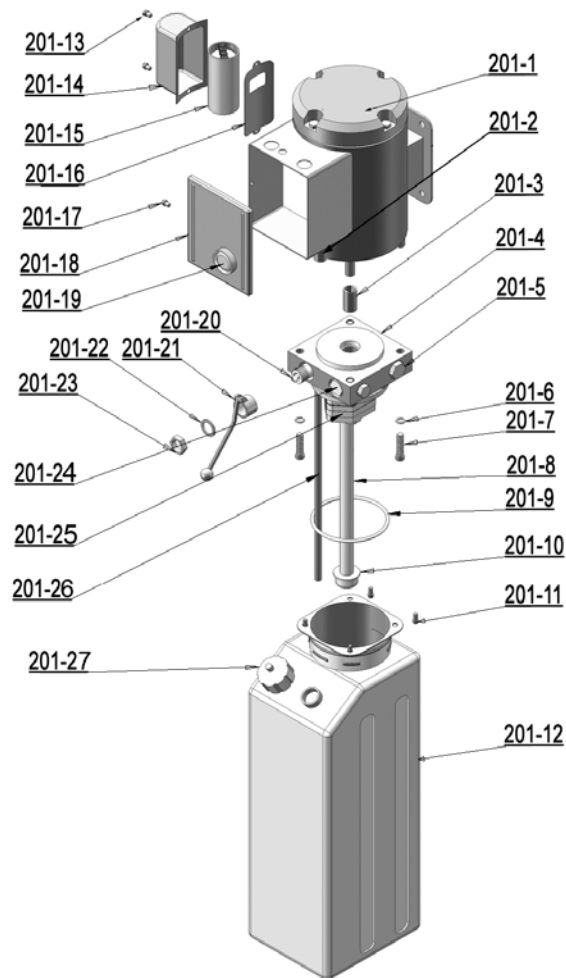
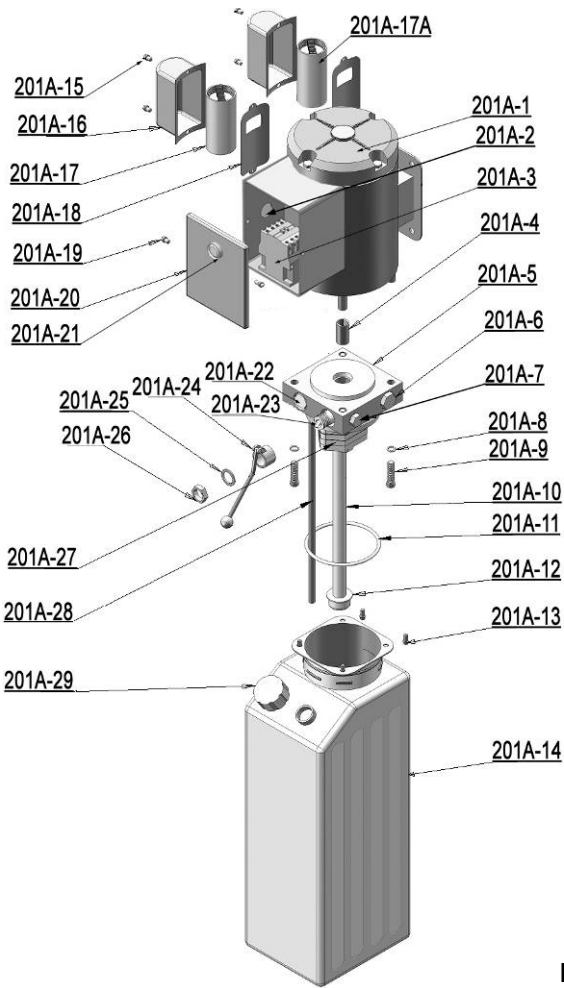

Fig. 35

PEAK MANUAL POWER UNIT

220V/50HZ/1 phase



380V/50HZ/3 phase

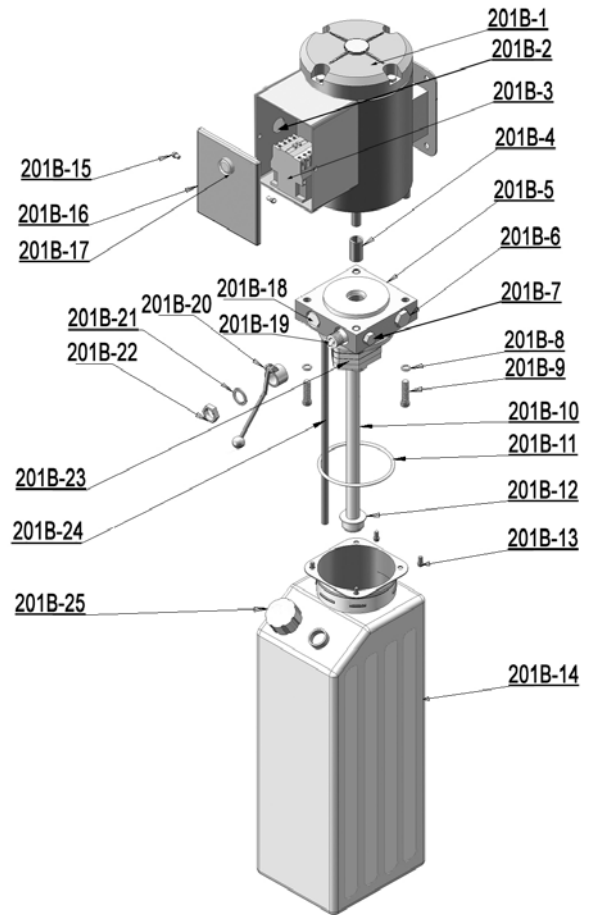

Fig. 36

Illustration of hydraulic valve for SPX & PEAK power unit

a. SPX manual power unit, 220V/50HZ, Single phase (See Fig. 42)



Fig. 37

b. PEAK manual power unit, 220V/50HZ, Single phase (See Fig. 38)

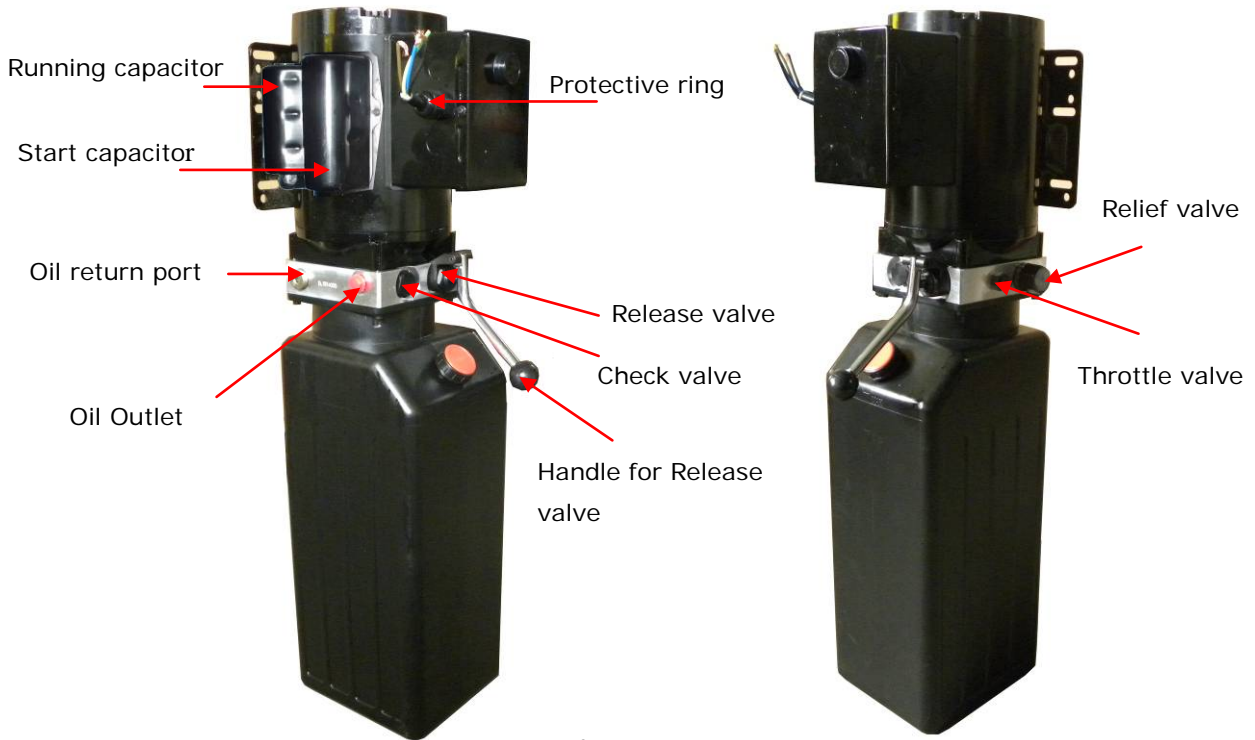

Fig. 38

C. PEAK manual power unit, 380V/50HZ, 3 phase (See Fig. 39)

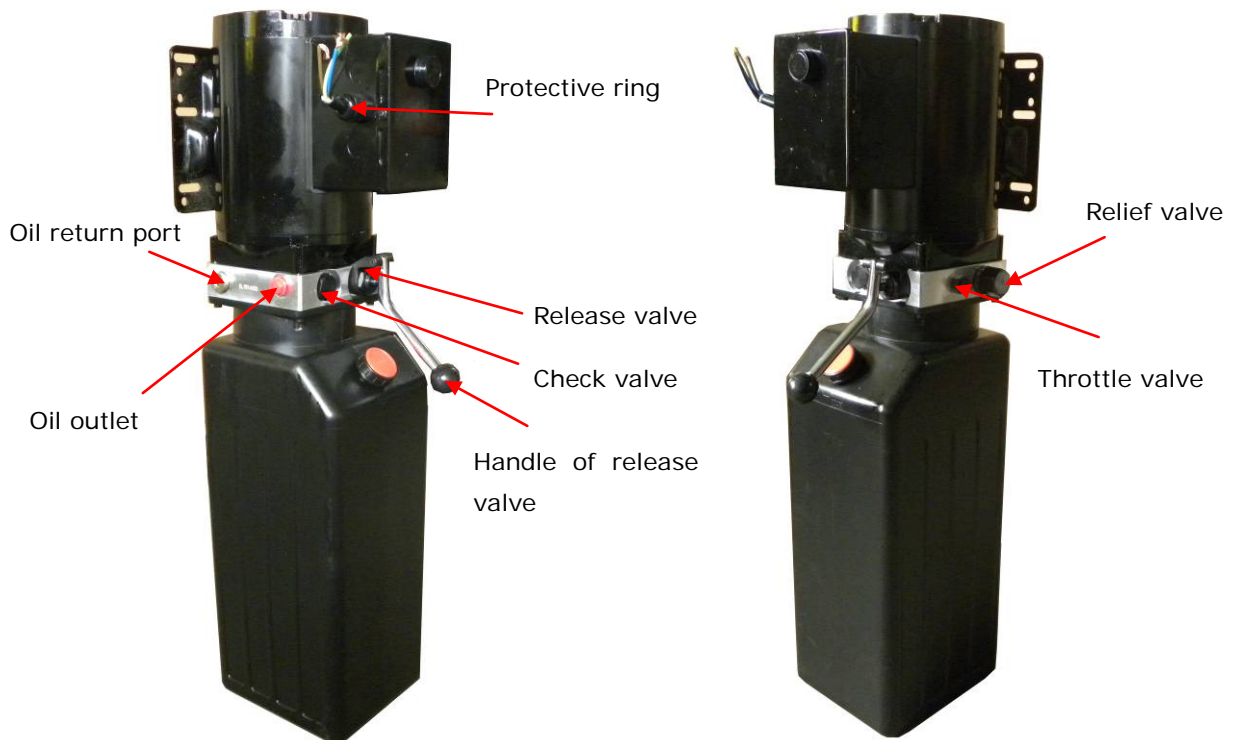

Fig. 39

V. TEST RUN

1. Adjust synchronous cable (See Fig. 40)

Use wrench to hold the cable fitting, meanwhile use ratchet spanner to tighten the cable nut.

Make sure two cables are with the same tension so that two carriages can work synchronously.

Fit the plastic hole cover on the lifting carriages.

If the carriages does not Synchronize when lifting, please tighten the cable nut of lower side carriage.

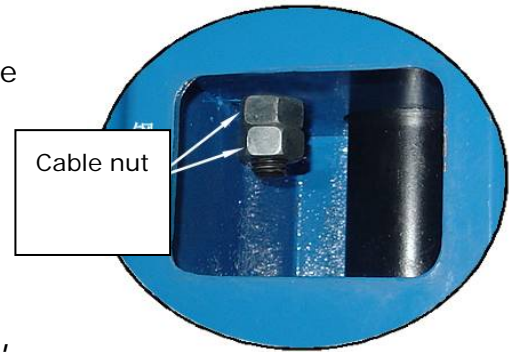

Fig. 40

2. Adjust safety cable

Lifting the carriages and lock at the same height, strain the safety cable and then release a little, and then tighten the cable nuts. Make sure the safety device can always be worked properly.

3. Bleeding air

This hydraulic system is designed to bleeding air by loosing the bleeding plug. Lifting the carriages to about 1 meter height, and loose the bleeding plug, the air would be bled automatically, then tighten the plug after bleeding, the lift would work stably and smoothly, otherwise repeat bleeding (See Fig. 41).



Fig. 41

4. Adjust the lower speed (Only for PEAK power unit)

You can adjust the lower speed of the lift if needing: Loosen the fixing nut of the throttle valve, and then turn the throttle valve clockwise to decrease the lower speed, or counterclockwise to increase the lower speed. Do not forget to tighten the fixing nut after the lower speed adjustment has been done.

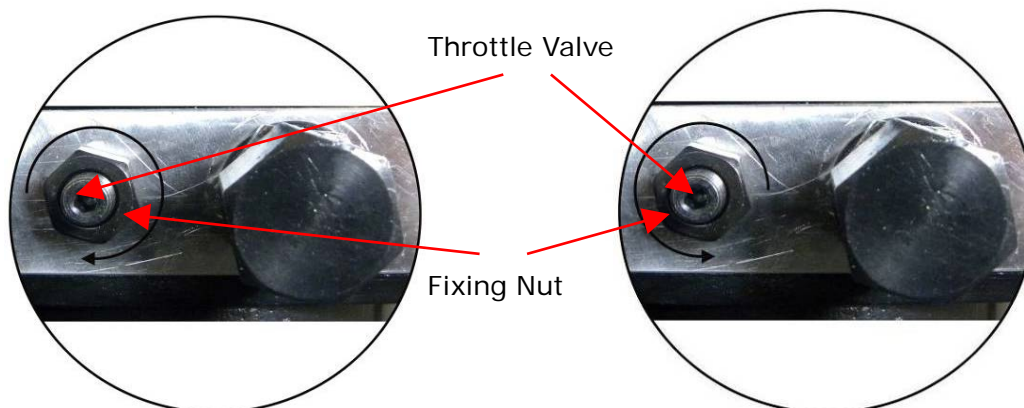

Clockwise to decrease the down speed

Fig. 42

Counterclockwise to increase the down speed

5. Test with load

After finishing the above adjustment, test running the lift with load. Run the lift in low position for several times first, make sure the lift can rise and lower synchronously, the safety device can lock and release synchronously. And then test run the lift to the top completely. If there are anything improper, repeat the above adjustment.

NOTE: It may be vibrated when lifting at start, lifting it with load for several times, the air would be bled and the vibration would be disappeared automatically.

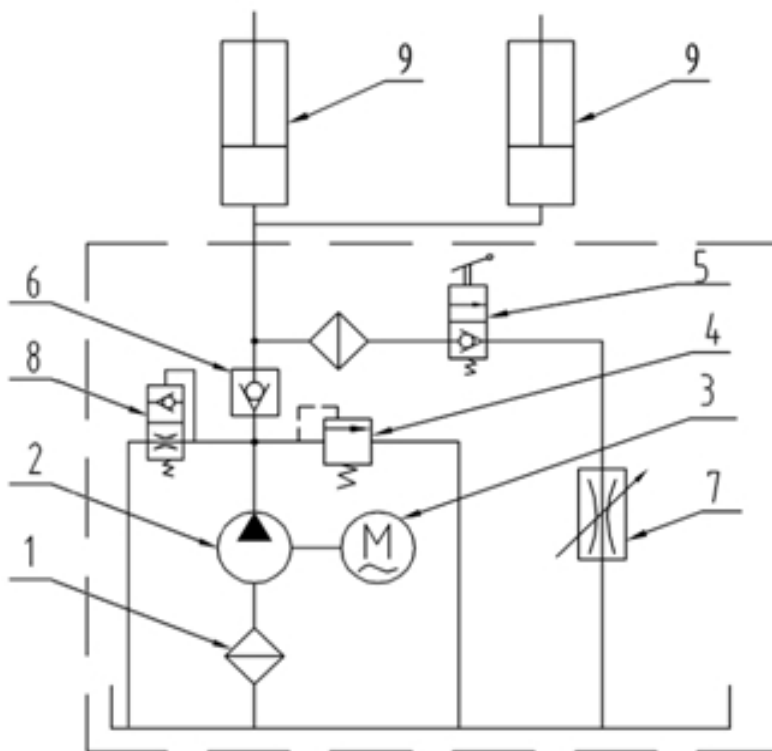

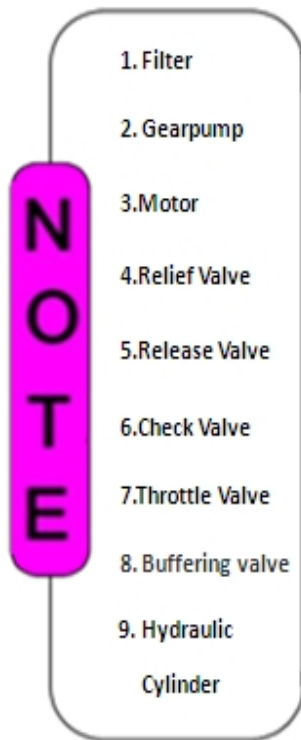

Fig. 43 Hydraulic System

VI. OPERATION INSTRUCTIONS

Please read the safety tips carefully before operating the lift

To lift vehicle

1. Keep clean of site near the lift;
2. Position lift arms to the lowest position;
3. To shortest lift arms;
4. Open lift arms;
5. Position vehicle between columns;
6. Move arms to the vehicle's lifting point;

Note: The four lift arms must at the same time contact the vehicle's lifting point where manufacturers recommended

7. Push button "**UP**" until the lift pads contact underside of vehicle totally. Recheck to

make sure vehicle is secure;

8. Continue to raise the lift slowly to the desired working height, ensuring the balance of vehicle;
9. Push lowering handle to lower lift onto the nearest safety. The vehicle is ready to repair.

To lower vehicle

1. Be sure clear of around and under the lift, only leaving operator in lift area;
2. Push button "UP" to raise the vehicle slightly, and then release the safety device, lower vehicle by pushing lowering handle.
3. Open the arms and position them to the shortest length;
4. Drive away the vehicle.
5. Turn off the power.

VII. MAINTENANCE SCHEDULE

Monthly:

1. Re-torque the anchor bolts to 150 Nm;
2. Check all connectors, bolts and pins to insure proper mounting;
3. Lubricate cable with lubricant;
4. Make a visual inspection of all hydraulic hoses/lines for possible wear or leakage;
5. Check safety device and make sure proper condition;
6. Lubricate all rollers and pins with 90wt. Gear oil or equivalent;

Note: All anchor bolts should take full torque. If any of the bolts does not function for any reason, DO NOT use the lift until the bolt has been replaced.

Every six months:

1. Make a visual inspection of all moving parts for possible wear, interference or damage.
2. Check and adjust as necessary, equalizer tension of the cables to insure level lifting.
3. Check columns for plumbness.
4. Check rubber pads and replace as necessary.
5. Check safety device and make sure proper condition.

VIII. TROUBLE SHOOTING

TROUBLE	CAUSE	REMEDY
---------	-------	--------

Motor does not run	<ol style="list-style-type: none"> 1. Button does not work 2. Wiring connections are not in good condition 3. Motor burned out 4. Height Limit Switch is damaged 5. AC Contactor burned out 	<ol style="list-style-type: none"> 1. Replace button 2. Repair all wiring connections 3. Repair or replace motor 4. Replace the Limit Switch 5. Replace AC Contactor
Motor runs but the lift is not raised	<ol style="list-style-type: none"> 1. Motor runs in reverse rotation 2. Gear Pump out of operation 3. Release Valve in damage 4. Relief Valve or Check Valve in damage 5. Low oil level 	<ol style="list-style-type: none"> 1. Reverse two power wire 2. Repair or replace 3. Repair or replace 4. Repair or replace 5. Fill tank
Lift does not stay up	<ol style="list-style-type: none"> 1. Release Valve out of work 2. Relief Valve or Check Valve leakage 3. Cylinder or Fittings leaks 	Repair or replace
Lift raises slowly	<ol style="list-style-type: none"> 1. Oil line is jammed 2. Motor running on low voltage 3. Oil mixed with Air 4. Gear Pump leaks 5. Overload lifting 	<ol style="list-style-type: none"> 1. Clean the oil line 2. Check electrical system 3. Fill tank 4. Replace Pump 5. Check load
Lift cannot lower	<ol style="list-style-type: none"> 1. Safety device are locking 2. Release Valve in damage 3. Safety cable broken 4. Oil system is jammed 	<ol style="list-style-type: none"> 1. Release the safeties 2. Repair or replace 3. Replace 4. Clean the oil system

IX. PARTS LIST FOR MODEL 210SAC

Item	Part#	Description	Quantity	Note
1	209206	Powerside Column	1	
201	209002	Manual Power Unit	1	
3	209003	Hex Bolt	4	
4	209004	Rubber Ring	4	
5	209005	Self locking Nut	4	
6	206002	Safety Pin	2	
7	209007	Safety Spring	2	
8	209008	Safety Cover	2	
9	209009	Cup Head Bolt	4	

10	209010	Snap Ring	1	
11	620059	Protective ring	1	
12	209049	Plastic small pulley	3	
13	209012	Hair Pin	8	
14	209013	Powerside Safety Lock	1	
15	206006	Washer	6	
16	206023A	Hex Nut	2	
17	209014	Cylinder	2	
17A	209111	Protective ring for cylinder	2	
18	209015	Slider Block	16	
19	209016	Carriage Plastic Cover	2	
20	209208	Carriage	2	
21	209018	Protective Rubber	2	
22	209019	Screw	12	
23	206156	Tool tray	2	
24	209021	Hex Nut	4	
25	209022	Washer	12	
26	217044	Arm lock	4	
26A	206154	Rear guard bar	2	
27	217046A	Arm lock bar(left)	2	
28	206036	Hair Pin	4	
29	217045	Spring	4	
30	206155	Front guard bar	2	
31	203131	Lifting Arm - Front (Drop-in)	2	
31A	203149	Outer Arm - Rear	2	
31B	203150	Inner Arm - Rear	2	
32	209212	Lifting Arm - Front left (Drop-in)	1	
32A	209220	Outer Arm - Front left	1	
32B	209222	Inner Arm - Front	1	
Item	Part#	Description	Quantity	Note
33	217168	Arm Pin	4	
33A	520023	Snap Ring	4	
34	206048	Socket Bolt	12	
35	209034	Lock Washer	16	
36	209033	Washer	16	
37	206049	Moon Gear	4	
38	209153	Pull tab for arm lock bar	4	
39	206032	Snap ring	4	
40	201002	Hex Bolt	12	
41	209039	Lock Washer	12	
42	217114A	Rubber Pad Assy.	4	

42A	420138	Socket bolt	4	
42B	209134	Rubber Pad	4	
42C	680030B	Rubber Pad Frame	4	
43	206025A	Foam Cushion	1	
44	201005	Split pin	2	
45	206025C	Connecting Pin for Control Bar	2	
46	202011	Control Bar	1	
47	206042	Control Bar Bracket	2	
48	206041	Hex Bolt	4	
49	206023	Self locking Nut	4	
50	206013	Limit Switch	1	
51	206011	Cup Head Bolt	2	
52	209184	Wire Cable	1	
53	211011	Top Beam	1	
54	209046	Hex Bolt	4	
55	209057A	Bronze Bush	6	
56	209057	Small Pulley	4	
57	209056	Self locking Nut	2	
58	209207	Offside Column	1	
59	211013	Offside Safety Lock	1	
60	209051B	Stackable Adapter(1.5")	4	
61	209052B	Stackable Adapter (2.5")	4	
62	209053B	Stackable Adapter (5")	4	
63	209054A	Stackable Adapter Bracket	2	
64	209055	Hex Bolt	6	
65	209044	Pin For Pulley	2	
66	209045	Big Pulley	2	
67	209059B	Anchor Bolt	12	
67A	620065	Shim	10	
67B	201090	Shim	10	
Item	Part#	Description	Quantity	Note
67C	209013	Lifting Arm-Front(Drop-in)	1	
67C-1	209221	Outer arm-Front right	1	
67C-2	209222	Inner arm-Front	1	
68	209060	90° Fitting for power unit	1	
69	211014	Oil hose	1	
70	211016	T- fitting	1	
71	211015A	Oil hose	2	
72	211017	Extend 90° fitting for Cylinder	2	
73	209066	Cable Nut	4	
74	211018	Cable	2	
75	211019	Safety Cable	1	

76	209501B	Parts Box	1	
77	217046	Arm Lock bar(right)	2	
17-1	209069	O-Ring	2	
17-2	209070	Bleeding Plug	2	
17-3	209071	Support Ring	2	
17-4	209072	Y-Ring	2	
17-5	209073	O-Ring	2	
17-6	209074	Piston	2	
17-7	209075	O-Ring	4	
17-8	209076	Piston Rod	2	
17-9	209077	Piston Rod Fitting	2	
17-10	209078	Dust Ring	2	
17-11	209079	Head Cup	2	
17-12	209080	O-Ying	2	
17-13	209081	Bore Weldment	2	

Item	Part#	Description	Quantity	Note
Parts for SPX manual power unit, 220V/50Hz/1 phase				
201-1	81400030	Motor	1	
201-2	81400159	Protective ring	1	
201-3	81400063	Motor connecting shaft	1	
201-4	81400031	Valve body	1	
201-5	81400160	Relief valve	1	
201-6	81400161	Lock washer	4	
201-7	81400162	Socket bolt	4	
201-8	81400121	Inlet pipe	1	
201-9	81400163	O-Ring	1	
201-10	81400164	Filter	1	

201-11	81400165	Hex Bolt	4	
201-12	81400093	Reservoir	1	
201-13	81400166	Head screw	2	
201-14	81400167	Cover of capacitor	1	
201-15	81400087	Capacitor	1	
201-16	81400168	Rubber gasket	1	
201-17	81400169	Hex Bolt	1	
201-18	81400062	Cover of motor terminal box	1	
201-19	81400028	Push button	1	
201-20	81400105	Release valve	1	
201-21	81400033	Handle for release valve	1	
201-22	81400170	Washer	1	
201-23	81400171	Hex Nut	1	
201-24	81400043	Check valve	1	
201-25	81400123	Gear pump	1	
201-26	81400122	Oil return pipe	1	
201-27	81400172	Filler cap	1	

Item	Part#	Description	Quantity	Note
Parts for PEAK manual power unit, 220V/50Hz/1 phase				
201A-1	81400048	Motor	1	
201A-2	81400178	Protective ring	1	
201A-3	81400179	AC contactor	1	
201A-4	81400127	Motor connecting shaft	1	
201A-5	81400067	Valve body	1	
201A-6	81400106	Relief valve	1	
201A-7	81400107	Throttle valve	1	
201A-8	209149	Lock washer	4	
201A-9	81400148	Socket bolt	4	
201A-10	81400134	Inlet pipe	1	

201A-11	81400144	O-Ring	1	
201A-12	81400150	Filter	1	
201A-13	81400145	Socket bolt	4	
201A-14	81400024	Reservoir	1	
201A-15	420148	Cup head bolt with washer	4	
201A-16	81400066	Cover of capacitor	2	
201A-17	81400130	Start capacitor	1	
201A-17A	81400088	Run capacitor	1	
201A-18	81400180	Rubber gasket	2	
201A-19	420148	Cup head bolt with washer	2	
201A-20	81400050	Cover of motor terminal box	1	
201A-21	81400045	Push button	1	
201A-22	81400044	Check valve	1	
201A-23	81400075	Release valve	1	
201A-24	81400117	Handle for release valve	1	
201A-25	81400181	Washer	1	
201A-26	81400182	Hex Nut	1	
201A-27	81400041	Gear pump	1	
201A-28	81400084	Oil return pipe	1	
201A-29	81400113	Filler cap	1	

Item	Part#	Description	Qty.		Note
Parts for PEAK manual power unit 380V/50Hz/3 phase					
201B-1	81400183	Motor	1	1	
201B-2	81400178	Protective ring	1	1	
201B-3	81400184	AC contactor	1	1	
201B-4	81400127	Motor connecting shaft	1	1	
201B-5	81400177	Valve body	1	1	
201B-6	81400175	Relief valve	1	1	
201B-7	81400107	Throttle valve	1	1	
201B-8	209149	Lock washer	4	4	
201B-9	81400148	Socket bolt	4	4	
201B-10	81400134	Inlet pipe	1	1	

201B-11	81400144	O-Ring	1	1	
201B-12	81400150	Filter	1	1	
201B-13	81400145	Socket bolt	4	4	
201B-14	81400024	Reservoir	1	1	
201B-15	420148	Cup head bolt with washer	2	2	
201B-16	81400050	Cover of motor terminal box	1	1	
201B-17	81400045	Push button	1	1	
201B-18	81400044	Check valve	1	1	
201B-19	81400075	Release Valve	1	1	
201B-20	81400117	Handle for release valve	1	1	
201B-21	81400181	Washer	1	1	
201B-22	81400182	Hex Nut	1	1	
201B-23	81400041	Gear pump	1	1	
201B-24	81400084	Oil return pipe	1	1	
201B-25	81400113	Filler cap	1	1	



PEAK CORPORATION

A2-A3 Xingui Industrial Area, Yanbu, Nanhai District,
Foshan(528247), China

Tel: 86-757-81102815 81102805

Fax: 86-757-81102809

Email: peak@peaklift.cn <http://www.peaklift.cn>

Manual Part NO.: 72121102

Revision Date: 11/2015